

- Efficient Operation
- Easy to Select and Install
- Quick Set-up through "EZ" Start
- Serial Communication
- Economical Configuration
- Bell & Gossett Excellence



70E Pressure Booster

PACKAGED SYSTEMS GROUP

D-215E

 **Bell & Gossett**
a xylem brand

Microprocessor Control Panel

- Exclusive Bell & Gossett Design
- Internal Diagnostics
- Differential Temperature No Flow Shut Down
- Automatic or Manual Operation
- NEMA 1 Enclosure
- UL listed
- cUL or CSA Certified
- IEC Magnetic Starters with Integral Overload Protection
- Fuses for Short Circuit Protection



Optional Features

- NEMA 4 or 12 Enclosure
- Low Level Cutout with Alarm (used when drawing from a tank)
- High Level Cutout (used when filling a tank)
- Differential Pressure switches (for pump failure indication)
- Flow Meter (for staging to flow or for gpm display)
- NEMA Starters
- Short Circuit Protection for Each Pump via Circuit Breakers
- Audible Alarm
- Flow Switch No Flow Shutdown
- Phase Monitoring
- Pressure Switch (for redundant low suction cutoff)

User-Friendly Operator Interface

- User Selectable Pump Staging Methods:
 - kW (True Power)
 - Amps (RMS)
 - Flow (GPM) (flow sensor required)
 - Pressure (PSI)
- “EZ” Start through Quick Setup
- Parameter Backup through Save and Load Menu
- On-screen Help Function
- On-line Diagnostics
- Log Menu
- Visual Alarm Messages
 - High and Low Suction Pressure Alarms
 - High and Low System Pressure Alarms
 - High Temperature Alarm
 - Overload Failure Alarm
- Manual or Automatic Pump Alternation
- Pump Exercise Feature
- kW and Amp Transducer with On-Board Calibration
- Real Time Clock
- Scheduled Start/Stop of System
- Elapsed Time Meters
- Suction and Discharge Pressure Displays
- Virtual H-O-A Switches

Energy Management System Interface

Hardwire Communication:

- Pump Run Indication
- Start/Stop Digital Input
- Alarm Indication
- System Auto/Manual Indication

Serial Communication:

- Above points plus –
- Pressure, Temperature and Power Measurement
- System Flow - with Optional Flow Meter
- Pump Alternation
- No Flow Shut Down Status

Factory Assembled Pressure Booster System

- Bell & Gossett Series 1531 Pumps
- Copper Headers with choice of end cap locations
- Cla-Val Pressure Reducing Valves
- Thermal Relief Mechanism
- Pump/PRV Isolation Valves
- UL Listed Pumping System

70E's Three-Step Selection Process

Step 1 System Demand: _____ GPM
 0-215 = 3" Up to 375 = 4" Up to 835 = 6"

Step 2 Required Pump Total Dynamic Head

1. System Discharge Pressure Required: _____ psig x 2.31 = _____ ft (A)
2. Pump Package Pressure Drop: 2.2 psig x 2.31 = 4.62 ft (B)
3. PRV Pressure Drop (*see Chart A*):
 Pump Flow – _____ GPM... _____ psig x 2.31 = _____ ft (C)
 (*Chart A*)

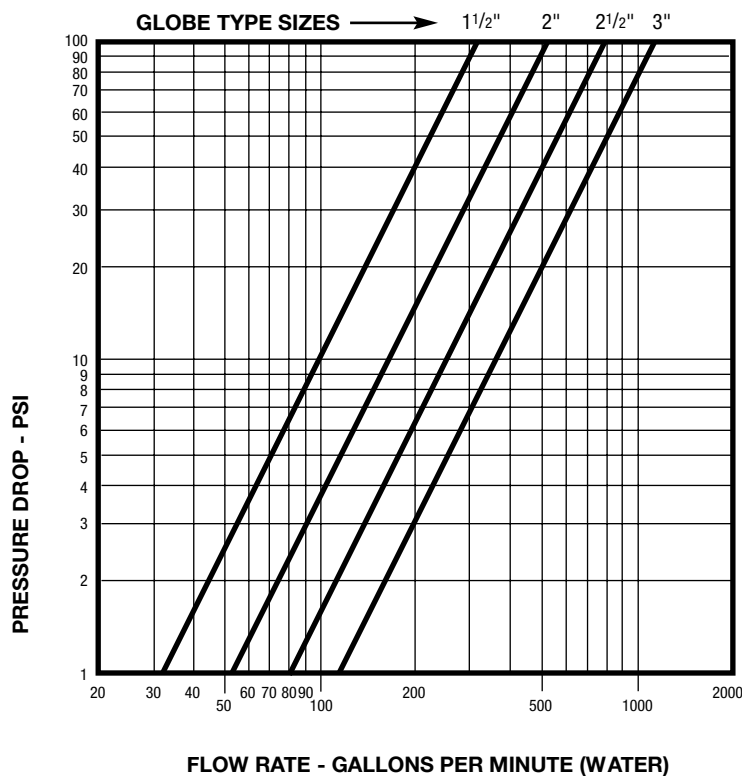

Chart A
PRV Pressure Drop

4. Suction Pressure from City Supply or Tank* _____ psig x 2.31 = _____ ft (D)
 *Note NPSH requirement of final pumps selected.

Required Pump Total Dynamic Head = A + B + C - D =

_____ ft + _____ ft + _____ ft - _____ ft = _____ ft (TDH)

Step 3

Use the ESP-Plus Pump Selection program or Bell & Gossett published pump curves to select pumps. If you cannot find a model number to fit your application, call your local Bell & Gossett representative for a booster that will fit.

70E 2-PUMP DIMENSIONS

MODEL # (see back cover)	A (max)	B (max)
21A, 2AA, 2KF, 2KG, 2RF, 2RG	51.13"	48.50"
22A, 22E, 29A, 29E, 2BA, 2BE	51.13"	54.00"
22B, 2BB, 2PA, 2PE	51.13"	54.00"
2JE, 2KF, 2QF, 2RF	51.38"	48.50"
23B, 23C, 23H, 2CB, 2CC, 2CH	51.38"	46.75"
24C, 24D, 24J, 2DC, 2DD, 2DJ	51.13"	48.38"
25A, 2EA	52.13"	54.75"
26B, 2FB, 2LA, 2LE, 2SA, 2SE	53.38"	56.63"
2ME, 2MF, 2TE, 2TF	52.50"	54.75"
2NF, 2NG, 2UF, 2UG	52.63"	54.75"
26A, 26E, 2FA, 2FE	53.75"	56.63"
27B, 27C, 27H, 2GB, 2GC, 2GH	52.50"	49.88"
28C, 28D, 28J, 2HC, 2HD, 2HJ	52.63"	49.25"

*C dimension is no greater than 36" for motor frame sizes of 284JP or less.

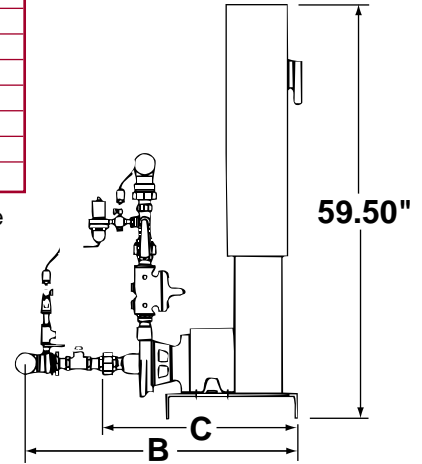
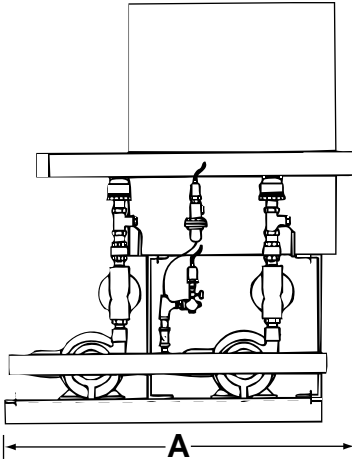

70E 3-PUMP DIMENSIONS

MODEL # (see back cover)	A (max)	B (max)
31A, 3AA	73.13"	48.50"
32A, 32B, 32E, 3BA, 3BB, 3BE, 39A, 39E	73.25"	54.00"
3PA, 3PE	73.25"	54.00"
3JE, 3JF, 3KF, 3KG, 3QE, 3QF, 3RF, 3RG	73.38"	48.50"
33B, 33C, 33H, 3CB, 3CC, 3CH	73.38"	46.63"
34C, 34D, 34J, 3DC, 3DD, 3DJ	73.38"	48.38"
35A, 3EA	74.13"	54.75"
36A, 36B, 36E, 3FA, 3FB, 3FE, 3LA, 3LE	74.38"	56.63"
3SA, 3SE	74.38"	56.63"
3ME, 3MF, 3NF, 3NG, 3TE, 3TF, 3UF, 3UG	74.50"	54.75"
37B, 37C, 37H, 38C, 38D, 38J, 3GB, 3GC	74.50"	49.88"
3GH, 3HC, 3HD, 3HJ	74.50"	49.88"

*C dimension is no greater than 36" for motor frame sizes of 284JP or less.

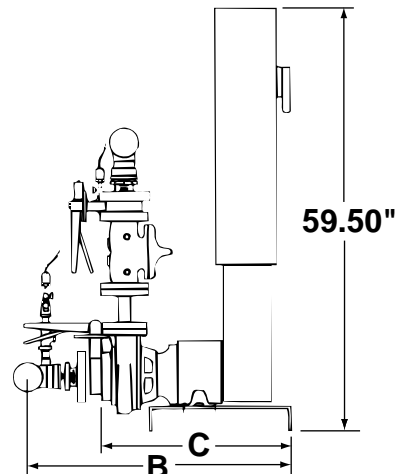
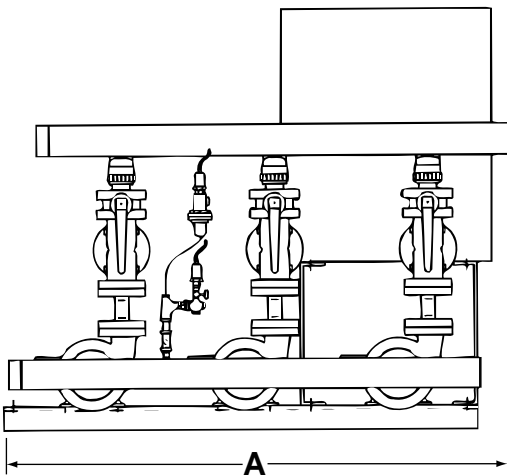

SUGGESTED SPECIFICATION FOR THE 70E PRESSURE BOOSTER

Furnish and install where shown on the drawings _____ 70E Pressure Booster System(s) Model number _____ as manufactured by Bell & Gossett. The electrical service to be provided shall be:
_____ Volts _____ Hertz _____ Phase.

Each unit shall have the capacity of _____ GPM at a discharge pressure of _____ psig when supplied with a minimum suction pressure of _____ psig.

Pumps shall have the following duty points:

- (1) _____ GPM @ _____ TDH w/ _____ HP, _____ RPM
- (2) _____ GPM @ _____ TDH w/ _____ HP, _____ RPM
- (3) _____ GPM @ _____ TDH w/ _____ HP, _____ RPM

The unit shall be constructed with copper headers type L. Unit shall be rated for 150 psig working pressure. Headers shall be constructed to be easily removed to allow for service access and moving the unit through doorways.

The unit shall be complete with Bell & Gossett Series 1531 horizontally mounted bronze fitted pumps. Pumps shall be rated for a minimum of 175 psig working pressure. Casings shall have gauge ports and vent and drain ports at top and bottom of casing. Motors shall meet NEMA specifications and shall be of the size, voltage, and enclosure called for on the plans. The pump manufacturer will be one in the same as the pressure booster manufacturer to ensure single source unit responsibility.

Entire package shall be constructed to UL Category QCZL Packaged Pumping Systems and listed by UL or equal prior to shipment.

A globe pattern, in-line combination pressure reducing (PRV) and check valve assembly shall be installed on each pump discharge. The valve shall have an epoxy coated body with a bronze disc. The valve pilot shall be direct acting, adjustable, spring-loaded, normally open diaphragm valve. Isolation valves shall be provided for each pump/PRV set.

Pumps shall be protected from thermal buildup, when running at no-flow, by a common thermal relief mechanism.

The Technologic solid state, programmable, constant speed pump logic controller shall be provided by Xylem Bell & Gossett. The controller shall be specifically designed for constant speed pressure boosting applications.

The controller shall be function to a proven program that safeguards against potentially damaging electrical and hydraulic conditions including:

- motor overload
- low level
- low and high suction pressure
- no flow
- low and high system pressure
- pump failure
- high system temperature

The entire pump logic controller assembly shall be listed and bear the label of a nationally recognized test lab. The pump logic controller shall be listed and bear the label of Underwriters Laboratories (UL), cUL or CSA.

The Pump logic controller shall be microcomputer based and hold its software in non-volatile memory. On-line field modified data entries, such as stage point, or method of staging, shall be stored in flash memory with capability to prevent accidental loss of data due to voltage surge or spike. In the event of a complete power outage, all factory preset data values remain stored and available for recall by the operator.

The pump logic controller shall be powered by 115V AC power from the control power transformer within the control enclosure. The control panel shall be equipped with a regulated 24VDC power supply to power analog input signals. The Pump logic Controller shall be capable of receiving four 4-20 mA analog input signals and two RTD signals.

The staging of pumps shall be user-selectable based on kilowatts (kW), current (Amps), flow (GPM) or pressure (PSI).

kW shall be true power derived from a B&G transducer. Amps shall be RMS from the kW transducer. Both kW and Amps shall be microcontroller calibrated with calibration held in non-volatile memory. PSI shall be derived from a B&G supplied pressure transducer with a 4-20 mA analog input. Optional flow shall be derived from a B&G supplied and calibrated transducer with a 4-20 mA analog input.

The control enclosure shall conform to NEMA 1 requirements and it shall include motor starters, overloads, control power transformer and microprocessor with NEMA 4 rated operator interface.

The pump logic controller shall alternate the pumps automatically based on a user defined time period, scheduled, manually from the operator interface, or via serial interface.

The Technologic controller shall have off line and on line diagnostic software. Off line diagnostics shall consist of CPU, non-volatile and RAM memory test. The controller shall have digital input diagnostics, display test, and analog and digital I/O user tests. Fault information may be accessed by interrogating the pump logic controller through its HELP and log keys.

A data-logging feature provides historical information of key events with date and time stamps. Log information includes alarms, pump run timers, system on/off times, and pump cycle counters. The data log displays the minimum, maximum and average values of temperature, pressure and flow. It is also capable of displaying kilowatt-hours.

The pump logic controller shall be powered by 115V/1Ph/60Hz or 50 Hz power. The incoming power and I/O circuitry shall reject electromagnetic (EMI) and radio frequency interference (RFI). All digital outputs shall be externally isolated.

The pump controller shall be capable of operation in ambient conditions of 0°C to +50°C and a humidity range of 10% to 90%, non-condensing.

All external sensors/transmitters and switches shall be powered by the pump logic controller through its integral 24VDC power supply. Over-voltage protection shall be on-board. All analog inputs shall be provided with current limit circuitry to provide short circuit protection and safeguard against incorrect wiring of sensors.

The pump logic controller shall operate the pump(s) in a pre-determined manner as indicated in the Sequence of Operation.

The controller's user interface shall contain a 4 line x 20 character liquid crystal display with 1/4" characters.

The pump logic controller shall be capable of operating in automatic, manual or off-line diagnostic modes. One level of password and software security shall be provided for protection of field modifiable data.

The pump controller shall be capable of communicating with the Building Automation System (BAS) by both hardwired and serial communications. The following communication features shall be provided to the BAS in hardwired form via digital outputs:

- Remote system start/stop input
- System alarm output
- Pump on/off status indication
- Auto/manual status indication

The following communication features shall be provided to the Building Automation System via an RS-485 port utilizing BACnet MS/TP, Johnson Controls Metasys N2, or Modicon Modbus protocols. LonWorks shall be provided through RS-232 port.

1. Individual analog inputs
2. Individual pump failure
3. Individual pump on/off status
4. Start/Stop command and status
5. System flow when optional flow sensor is provided
6. Pressure, Temperature, Power measurement
7. General alarm indication
8. No flow shutdown status
9. Pump alternation

The pump logic controller shall provide the following standard user-selectable features:

- low suction pressure alarm and cut out
- high suction pressure alarm and cut out
- low system pressure alarm
- high system pressure alarm and cut out
- visual alarm messages
- no-flow shut down
- pump failure alarm
- high temperature alarm and cut out
- low level alarm and cut out
- overload failure alarm
- automatic or manual alternation

70E MODEL NUMBER IDENTIFICATION

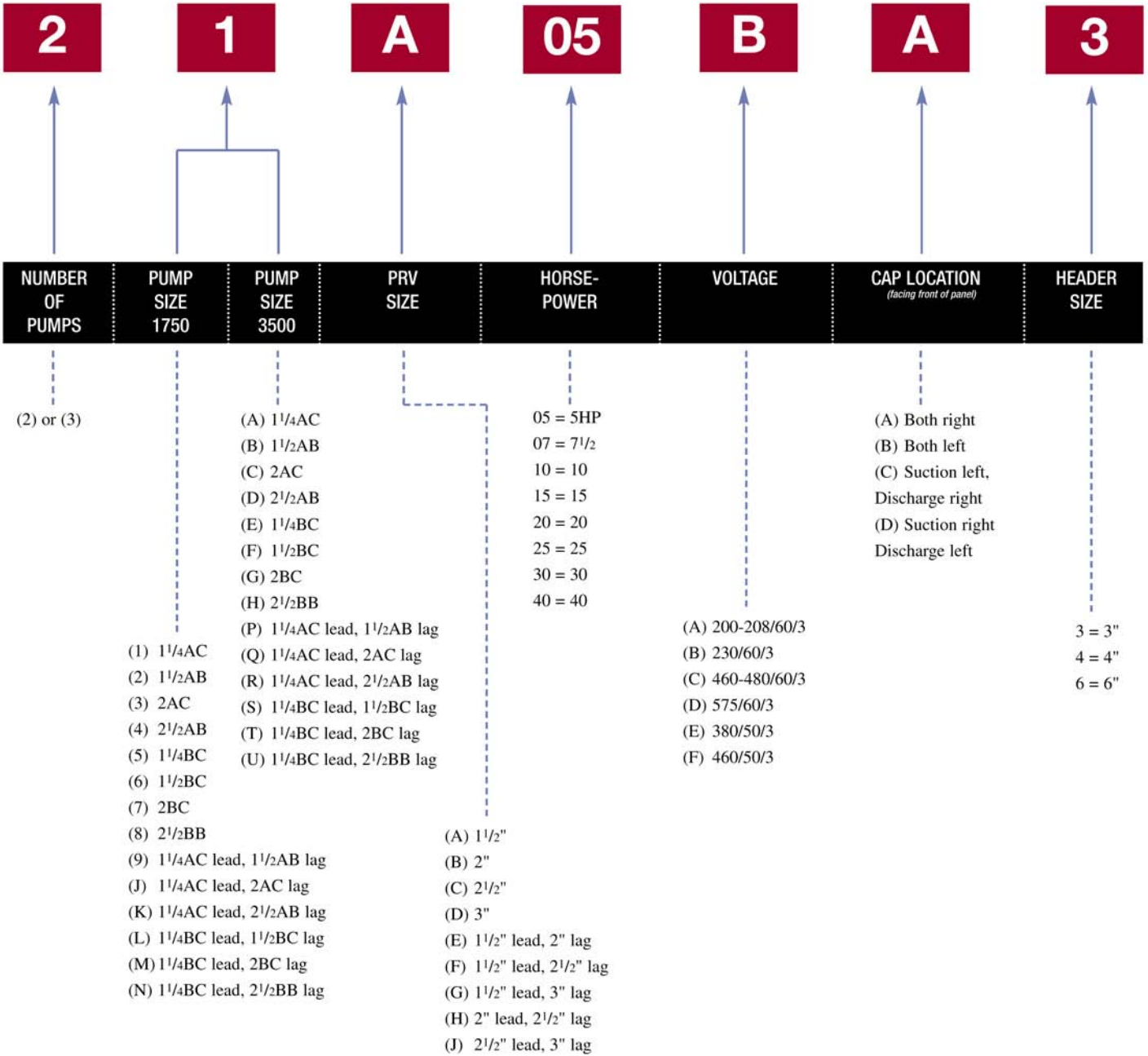

Xylem |'zīləm|

- 1) The tissue in plants that brings water upward from the roots;
- 2) a leading global water technology company.

We're 12,500 people unified in a common purpose: creating innovative solutions to meet our world's water needs. Developing new technologies that will improve the way water is used, conserved, and re-used in the future is central to our work. We move, treat, analyze, and return water to the environment, and we help people use water efficiently, in their homes, buildings, factories and farms. In more than 150 countries, we have strong, long-standing relationships with customers who know us for our powerful combination of leading product brands and applications expertise, backed by a legacy of innovation.

For more information on how Xylem can help you, go to www.xyleminc.com



Xylem Inc.
10661 Newkirk Street
Dallas, TX 75220
Phone: 800-786-7480
www.xyleminc.com/brands/bellgossett

Bell & Gossett is a trademark of Xylem Inc. or one of its subsidiaries.
© 2012 Xylem Inc. D-215E May 2012