

Series 60[®] In Line Centrifugal Pump

INSTRUCTIONS FOR:

INSTALLATION
OPERATION
SAFETY
SERVICE



**INSTALLER: PLEASE
LEAVE THIS MANUAL
FOR THE OWNER'S USE.**

DESCRIPTION

The Series 60 pump is the culmination of compact design, quiet operation, low maintenance and, of course, Bell & Gossett quality. The compact design of the Series 60 centrifugal pump facilitates direct in-line mounting. The sleeve bearings, flexible couplers and rubber ring mounted motors provide smooth operation with minimal noise. The back pull-out assembly feature provides ease to all service operations. The combination of these features make the Series 60 ideal for many primary and secondary applications.

The Series 60 is available in sizes from 1" to 2.5" to meet a range of system pipe specifications. Equally versatile is the Series 60's availability at several power levels – ranging from 1/4 to 3 HP at 1750 RPM in BF, AI and AB construction. Combining these parameters makes possible the achievement of flow rates to 180 gpm and heads to 62 feet.

OPERATIONAL LIMITS

B&G Series 60 Pumps are designed to pump liquids compatible with their iron or bronze body construction at working pressures up to 175 psi and a maximum temperature of 225°F. Do not exceed these values.

Pump Construction:

Bronze Fitted or All Bronze or All Iron
Standard Mechanical Seal

Motors:

208-230/460 Volts – Three Phase
115/230 Volts – Single Phase
(w/built-in overload protection).

Mechanical Seal:

Standard: BUNA – PH Limitations 7-9;
Temperature Range –40 to + 225°F
Optional: EPT – PH Limitations 7-11;
Temperature Range –40 to + 250°F

PUMP APPLICATION

Bell & Gossett Centrifugal Pumps may be used for hydronic heating and cooling systems, domestic water, industrial applications and general service operations. Bell & Gossett recommends that bronze constructed pumps be used for pumping potable water. This pump is for indoor use only.



SAFETY INSTRUCTIONS

This safety alert symbol will be used in this manual and on the pump instructions decal to draw attention to safety related instructions. When used, the safety alert symbol means **ATTENTION! BECOME ALERT! YOUR SAFETY IS INVOLVED! FAILURE TO FOLLOW THE INSTRUCTIONS MAY RESULT IN A SAFETY HAZARD.**



Your Series 60 Pump should have this warning label affixed to the pump near the conduit box cover. If this warning is missing or illegible, contact your local Bell & Gossett Representative for a replacement.

SAFETY REQUIREMENTS

ELECTRICAL SAFETY



WARNING: ELECTRICAL SHOCK HAZARD.

Electrical connections to be made by a qualified electrician in accordance with all applicable codes, ordinances and good practices. Failure to follow these instructions could result in serious personal injury, death and/or property damage.



WARNING: ELECTRICAL SHOCK HAZARD.

Three phase motors must have properly sized heaters to provide overload and under voltage protection. Single phase motors have built-in overload protectors. Failure to follow these instructions could result in serious personal injury, death and/or property damage.

THERMAL SAFETY



WARNING: EXTREME TEMPERATURE HAZARD.

If the pump, motor, or piping are operating at extremely high or low temperature, guarding or insulation is required. Failure to follow these instructions could result in serious personal injury, death and/or property damage.



WARNING: HOT WATER HAZARD.

When disassembling a gasketed joint, always use a new gasket upon reassembly. NEVER RE-USE OLD GASKETS. Failure to follow these instructions could result in serious personal injury, death and/or property damage.

MECHANICAL SAFETY



WARNING: UNEXPECTED START-UP HAZARD.

Disconnect and lockout power before servicing. Failure to follow these instructions could result in serious personal injury, death and/or property damage.



WARNING: EXCESSIVE SYSTEM PRESSURE HAZARD.

The maximum working pressure of the pump is listed on the nameplate – DO NOT EXCEED THIS PRESSURE. Failure to follow these instructions could result in serious personal injury, death and/or property damage.



WARNING: EXCESSIVE PRESSURE HAZARD –

VOLUMETRIC EXPANSION. The heating of water and other fluids causes volumetric expansion. The associated forces may cause failure of system components and release high temperature fluids. This can be prevented by installing properly sized and located compression tanks and pressure relief valves. Failure to follow these instructions could result in serious personal injury, death and/or property damage.

PUMP INSTALLATION

PUMP SUPPORT AND LOCATION

The Bell & Gossett Series 60 pump should be installed where there will be sufficient room for future inspection, maintenance and service. It is highly recommended that service valves (shut-off) also be installed on each side of circulator pumps to facilitate servicing or replacing the pump without draining the system. Special precautions should be taken to avoid sound and vibration transmission. If the pump is to be located near a noise sensitive area, consult a sound specialist.

If it is required to lift the entire pump, do so with slings placed around the pump assembly as shown.

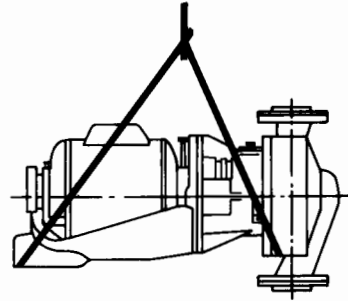

IMPORTANT: In closed systems, do not install and operate Bell & Gossett pumps, 3D valves, suction diffusers, etc., without properly sized safety and control devices. Such devices include the properly sized and located pressure relief valves, compression tanks and pressure, temperature, and flow controls. If the system is not equipped with these devices, consult the responsible engineer or architect before operating.

MODE OF DISCHARGE

B&G Series 60 In-Line pumps can be installed to discharge up, down, left or right. The oiling ports must always be in the twelve o'clock position (on top) with the motor and bearing assembly in a horizontal position. THE ARROW ON THE PUMP BODY MUST POINT IN THE DIRECTION OF THE FLOW.

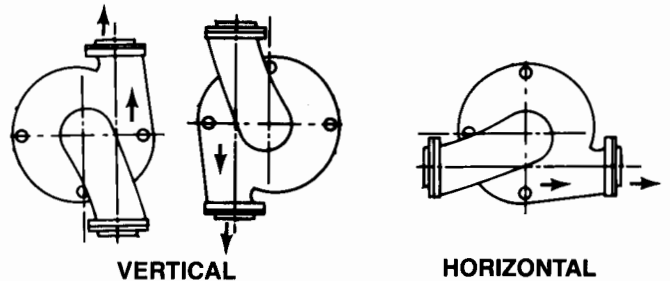
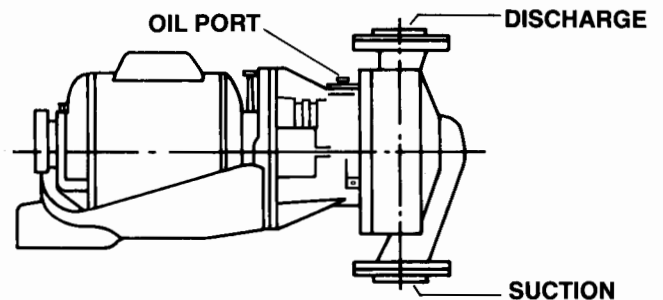

OPERATIONAL INSTRUCTIONS

SYSTEM PREPARATION

Prior to pump start up, closed heating and cooling systems should be flushed and drained with clean water. The system should then be filled with clean water having a PH between 7 and 9.

LUBRICATION

All new B&G pumps are test run at the factory, but must be lubricated thoroughly before being placed in operation. Bell & Gossett supplies a high quality lubricant specifically for this purpose which can be purchased from any B&G Representative (Part No. L23401), Proper lubrication procedures are as follows:

1. PUMP BEARINGS –

Fill the bearing frame according to the oiling instruction decal. At the time of installation or start of each heating season, add approximately 1 oz. of B&G #20 weight non-detergent oil. A SAE 20 (non-detergent) or 10W-30 oil may be substituted. More frequent lubrication may be required under adverse conditions such as high ambient temperatures.

2. MOTOR BEARINGS –

Sleeve Bearings: Lubricate through the motor oil cups per the lubrication decal once every four months or more often under adverse conditions. Use eight to ten drops in each oil cup.

Ball Bearings: Lubricate every six months to two years depending on conditions with soda soap or lithium base grease.

For Non-Bell & Gossett Motors, lubrication should be in accordance with the motor manufacturer's instructions on the nameplate.

ROTATION

Pump rotation is clockwise when viewed from the back of the motor. An arrow is provided to show the rotational direction.

PRIMING AND STARTING



CAUTION: SEALED DAMAGE HAZARD.

Do not run the pump dry – seal damage may occur. Failure to follow these instructions could result in moderate personal injury and/or property damage.

Before starting, the Series 60 pump must be filled with water. Manual priming may be necessary if the system does not fill the pump body automatically. Vent plugs are provided on the pump body to vent the air.



WARNING: HOT WATER LEAKAGE HAZARD.

Pressurize the pump body slowly while checking for leaks at all joints with gaskets. Failure to follow these instructions could result in serious personal injury and/or property damage.

The pump should be started with the discharge valve closed and the suction valve fully open. After the pumps is at operating speed, the discharge valve should be opened gradually.

SERVICE INSTRUCTIONS

GENERAL INSTRUCTIONS

1. Keep the pump and motor properly lubricated.
2. If the pump is to be exposed to freezing temperature, drain the pump.

PERIODIC INSPECTION

Inspect the pump regularly for leaking seals, worn gaskets, and loose or damaged components. Replace or repair as required.

REPLACING THE SEAL

DISCONNECT THE ELECTRICAL SUPPLY



WARNING: ELECTRICAL SHOCK HAZARD.

Disconnect and lockout the power before servicing. Failure to follow these instructions could result in serious personal injury or death.

The electrical supply must be turned off and the pump service valves must be closed before servicing procedures begin. If no service valves are installed, the city water supply valve should be closed.



WARNING: ELECTRICAL SHOCK HAZARD.

Be certain the electrical power is not present at the motor leads before continuing. Failure to follow these instructions could result in serious personal injury or death.



WARNING: UNEXPECTED START-UP HAZARD.

Disconnect and lockout power before servicing. Failure to follow these instructions could result in serious personal injury, death and/or property damage.

Loosen the conduit box cover screws and remove the cover. Follow this procedure with the removal of the wire nuts and flexible conduit connector.

REMOVE THE MOTOR AND BEARING ASSEMBLY



WARNING: HOT WATER HAZARD.

Before draining the system, allow water to cool to at least 100°F, open the drain valve (take precautions against water damage) and leave the drain valve open until servicing is complete. Failure to follow these instructions could result in serious personal injury, death and/or property damage.

The system should be drained by opening the boiler drain valve and the vent near the top of the system. If a Flo-control valve is installed and there are balance valves on the returns, then the balance valves may be closed to isolate the boiler from the system. The Flo-Control valve will act as a check valve on the supply and only the boiler will need to be drained. Open a vent between the boiler and the system.

SYSTEM PIPING

Always install a section of straight pipe between the suction side of the pump and the first elbow. The length of this pipe should be equal to five times the diameter of the suction pipe size. This reduces turbulence of the suction by straightening the liquid flow path prior to pump entry.

Air must be kept out of the system. On an open system always place the end of the suction pipe at least three feet (3') below the surface of the water in the suction well to prevent air from being drawn into the pump. Avoid air pockets in the suction line and ensure that each section of the suction pipe is absolutely air tight.

If high temperature variation is anticipated, expansion fittings should be installed such that they reduce pump strain.

Install the suction and discharge flanges on the pipe ends using teflon tape sealer or high quality thread sealant. Minimize strain on the pump by supporting the suction and discharge piping with pipe hangers near the pump. Line up the vertical and horizontal piping so that the bolt-holes in both the pump and pipe flanges are aligned. **DO NOT ATTEMPT TO SPRING THE SUCTION OR DISCHARGE LINES INTO POSITION. THIS MAY RESULT IN UNWANTED STRESS IN THE PUMP BODY, FLANGE CONNECTIONS AND/OR PIPING.** The code for pressure piping, ANSIB31.1, lists types of supports available for various applications.

Ordinary wire or band hangers are not adequate to maintain alignment. It is very important to provide strong, rigid support for the suction and discharge lines.

New Bell & Gossett flange gaskets must be installed between the flanges of the pump body and suction and discharge pipes. The gaskets should be clean and grease-free; old gaskets should never be reused. Suitable fasteners for this connection are supplied in the B&G fastener pack. Apply a torque of 8-11 ft. lbs. to each of the flange bolts. Both the suction and discharge flanges must be torqued to the same level.



WARNING: HOT WATER LEAKAGE HAZARD.

Make certain that the flange bolts have been adequately torqued. Failure to follow these instructions could result in serious personal injury and/or property damage.

WIRING INSTRUCTIONS



WARNING: ELECTRICAL SHOCK HAZARD.

Disconnect and lockout the power before making electrical connections. Failure to follow these instructions could result in serious personal injury or death.

Remove the screws securing the conduit box cover (wiring compartment) and lift off the cover. Attach the appropriate size connector to the hole in the side of the conduit box.

I. SINGLE PHASE MOTORS

The single phase motor can operate at low voltage (115V) as well as at high voltage (230V). Determine the voltage at which you choose to operate your B&G pump and make wiring connections according to the following diagrams (these diagrams are also found in the conduit box cover):

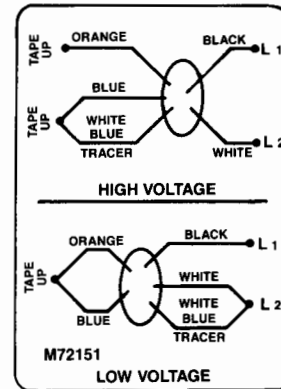

NOTE: Bell & Gossett Single Phase Motors are protected with inherent overheating devices and do not require external overload protection.

II. THREE PHASE MOTORS

The Series 60 three phase motors can operate at either low voltage (208-230V) or at high voltage (460V). Determine the voltage you choose to operate your B&G pump. Wiring instructions for each option is listed below and is also found in the conduit box cover.

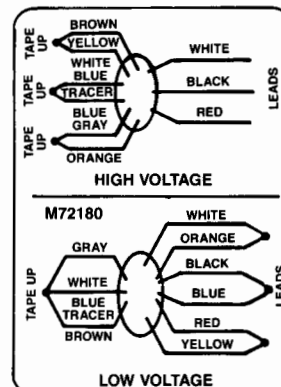

WARNING: Be certain that all connections are secure and the conduit box cover is closed before electrical power is connected. Failure to follow these instructions could result in serious personal injury, death and/or property damage.



WARNING: HIGH PRESSURE HAZARD.

Pressure may be present in the pump body. This pressure can be relieved by loosening the eight volute capscrews and shifting the bearing assembly slightly to allow the pressurized water to escape. Failure to follow these instructions could result in serious personal injury or death.

Separate the bearing assembly and motor from the pump body by removing the eight volute capscrews from the cover-plate (see diagrams below).

DETERMINE THE SEAL TYPE

Cut away diagrams have been provided to illustrate the components of the Series 60 bearing assemblies. The primary feature distinguishing the mechanical seals of the AA type pumps from the A and F types is the addition of a retainer cup seated atop the spring of all AA type pumps. Refer to these diagrams whenever seal replacement becomes necessary.

PUMP BODY DIAGRAM

1AA, 1 1/4"AA, 1 1/2"AA and 2"AA

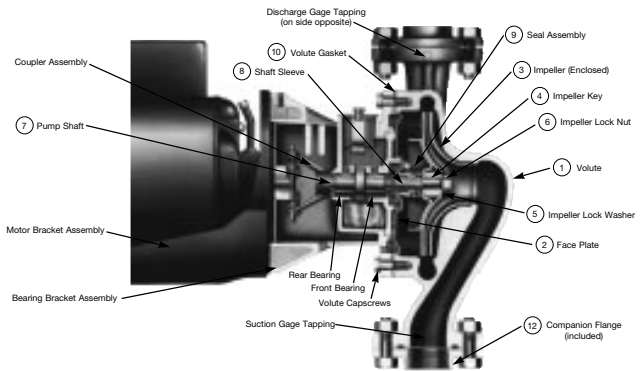

1AA, 1 1/4"AA, 1 1/2"AA and 2"AA construction details

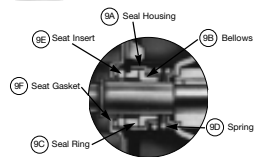

Mechanical Seal

PUMP BODY DIAGRAM

1 1/2"A, 2"A, and 2 1/2"F

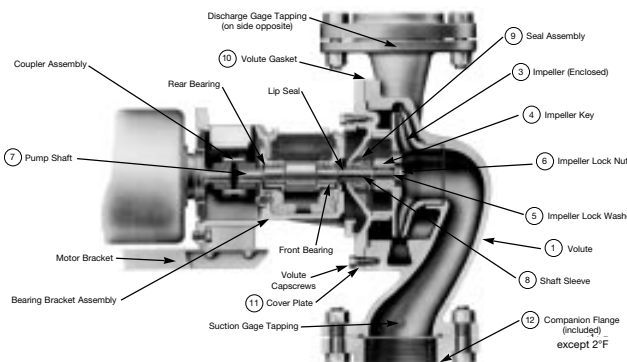

1 1/2"A, 2"AA, and 2 1/2"F construction details

REPLACEMENT PROCEDURE

With the bearing assembly and motor removed from the system, use the following instructions to facilitate the replacement.

1. Use a strap wrench or rag to prevent the impeller from turning with one hand and loosen the impeller nut with the other.
2. Lift the spring retainer (for AA type motors only) and the seal spring from the shaft. Remove the compression ring from the seal collar by inserting a small screwdriver underneath the ring a carefully applying an upward prying force. Remove the ring, collar and the remaining seal components from the shaft.

NOTE: Bell and Gossett seal assemblies consist of an insert retainer, rubber gasket, ceramic insert, carbon seal ring, rubber collar, brass collar and compression ring. Each of these components must be replaced when replacing the mechanical seal. NEVER REPLACE INDIVIDUAL COMPONENTS SEPARATELY.

3. Using a clean, lint free rag, remove any debris that may have accumulated in the seal recess.
4. Place the new retainer in the bearing assembly's seal recess. Seat the thin rubber gasket in the recess and set the ceramic insert atop the gasket. The ceramic has a top side and bottom side. The bottom is identifiable by its slightly recessed grooves. These grooves should face downward toward the rubber gasket.
5. Before proceeding, place the shaft end on a wooden block; the wooden block should push the shaft to its forward-most position (there should not be any end-play in the shaft).
6. Lubricate the rubber seal collar with soapy water. The entire rotating seal assembly, which includes the carbon seal ring, rubber collar, brass collar and compression ring, is to be pushed onto the shaft as one unit. Do not attempt to assemble the seal by placing the components on the shaft individually. The notches in the brass collar should be aligned with the recesses found on each side of the carbon insert.
7. Press the brass compression ring tightly against the upper end of the rubber collar. A screwdriver can be used at several points along its periphery to provide a tight and even fit. Press with the screwdriver – do not tap. Tapping on the seal may break the ceramic or carbon insert.

8. With shaft resting on the wooden block, place the seal spring on the shaft (and cup retainer for AA size pumps). Next, place the impeller and lockwasher. Thread the impeller nut to the shaft and tighten with 96-144 in-lbs of torque. Consult the TORQUE CHART on next page. Do not overtighten.



WARNING: HOT WATER HAZARD.

Whenever the bearing assembly is removed from the piping, use a new gasket when re-installing. Failure to follow these instructions could result in serious personal injury and/or property damage.

9. Clean the pump body of excess debris. Place a new gasket in the recess of the pump body; ensure that it sits flush against the gasket surface.

SEAL REPLACEMENT (continued)





10. Replace the motor and bearing assembly by inserting the impeller in the pump body and evenly tighten the eight capscrews. Refer to the TORQUE CHART below.
11. Refer to the WIRING INSTRUCTIONS section in this manual to properly configure all electrical connections.
12. Follow the OPERATIONAL INSTRUCTIONS in this manual to:
 - a. check the PH of the system water,
 - b. to check the rotation of the pump and,
 - c. to prime the system prior to starting.

ADDITIONAL PUMP REPAIR

Refer to the following manual for further repair instructions for the Bell & Gossett Series 60 pump:

Coupler & Motor Mount Replacement. . . #P06452

TORQUE CHART

Capscrew Type	Head Marking	CAPSCREW TORQUE (FOOT-POUND)								
		Capscrew Diameter								
		1/4	5/16	3/8	7/16	1/2	5/8	3/4	7/8	1
SAE Grade 2		6	13	25	38	60	120	190	210	300
Brass Stainless Steel	 or 	4	10	17	27	42	83	130	200	300
SAE Grade 5		10	20	35	60	90	180	325	525	800

YOUR BELL & GOSSETT REPRESENTATIVE IS...

DEALER SERVICING

If your pump requires further repair, contact your local B&G Representative. Having the following information at hand will facilitate your representative's ability to assist you:

1. Complete data from nameplate.
2. Suction and discharge pipe pressure gauge readings.
3. Ampere draw of motor.
4. A sketch of the pumping system (include pipes, valves, etc.)

Ensure Quality and Performance with ...

GENUINE BELL & GOSSETT REPLACEMENT PARTS

For further information, contact ITT Bell & Gossett, 8200 N. Austin Avenue, Morton Grove, IL 60053, Phone (847) 966-3700 – Facsimile (847) 966-9052.

ITT Bell & Gossett
Morton Grove, IL, U.S.A.