

CLARKE FIRE PUMP DRIVERS  
EPA NSPS TIER 3 ENGINE MODELS  
VT APPLICATIONS

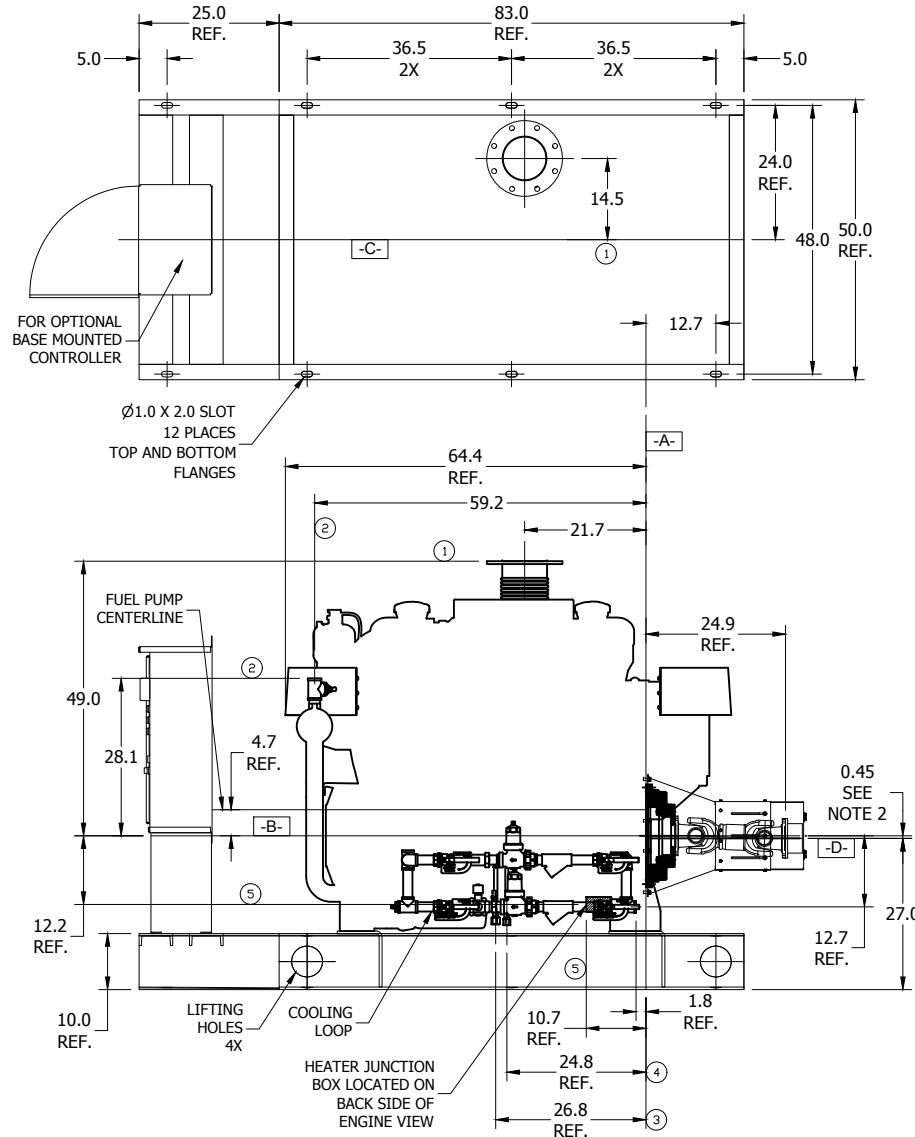

Vertical Pumps

- A- - MOUNTING FACE OF FLYWHEEL
- B- - ENGINE CRANKSHAFT HORIZONTAL CENTERLINE
- C- - ENGINE CRANKSHAFT VERTICAL CENTERLINE
- D- - PUMP SHAFT HORIZONTAL CENTERLINE



NON-LISTED DRIVESHAFTS	
ENGINE MODEL	DRIVESHAFT MODEL
C18H0-UFAD10,18,20,28,30,38,40,48,50**,68,70**	SC2160A
C18H0-UFAD50*,58,70*,78	SC2390A

\*1900 RPM ONLY, \*\*2100 RPM ONLY

ITEM NO.	DESCRIPTION	CONNECTION SIZE
①	EXHAUST OUTLET CONNECTION	8" 150# FLG.
②	RAW WATER OUTLET	SEE NOTE 6.
③	FUEL SUPPLY CONNECTION	3/4" NPTF
④	FUEL RETURN CONNECTION	1/2" NPTF
⑤	HEATER JUNCTION BOX	VOLTAGE REQUIREMENTS: AC CONNECTION HEATER 3500 WATTS STD- 230 VAC ±5%-10%

NOTES:

1. GENERAL TOLERANCE: UNLESS OTHERWISE SPECIFIED, ALL DIMENSIONS ARE IN INCHES AND VARY 0.38".
2. THE DRIVE SHAFT IS DESIGNED TO OPERATE AT A 2° ANGLE WITH THE INPUT AND OUTPUT SHAFTS IN PARALLEL. THE ENGINE CRANKSHAFT IS TO BE SET WITH A PARALLEL OFFSET OF 0.45 ± 0.15 INCHES VERTICALLY ABOVE THE PUMP SHAFT AND 0.00" ± 0.15 INCH PARALLEL OFFSET HORIZONTALLY RIGHT OR LEFT OF THE PUMP SHAFT. REFER TO THE CERTIFIED DRIVESHAFT INSTRUCTIONS MANUAL FOR ALIGNMENT INSTRUCTIONS.
3. BASE MUST BE COMPLETELY FILLED WITH GROUT PER NFPA 20.
4. PUMP IS CW (CLOCKWISE) ROTATION WHEN VIEWED FROM THE COUPLING END.
5. SUCTION AND DISCHARGE FLANGES DRILLED PER ANSI B16.1 (IF APPLICABLE).
6. RAW WATER OUTLET SIZE VARIES BASED UPON SITE CONDITIONS. DEFAULT SIZE: 1-1/2" NPT
7. CAUTION: ALL PLUMBING MUST BE SUPPORTED AND/OR ISOLATED SO THAT NO WEIGHT OR STRESS IS APPLIED TO ANY ENGINE COMPONENT.
8. CAUTION: SPREADER BARS REQUIRED TO MOVE PACKAGE. DAMAGE DUE TO IMPROPER HANDLING IS NOT WARRANTABLE.

Certified for:  Approval  Construction By: \_\_\_\_\_ Date: \_\_\_\_\_ Listed:  UL  FM

Project:	Capacity:	Engine Supplier: CLARKE
Customer:	Total Pressure:	Engine Model:
Item / P.O. No.:	Pump Speed:	Engine Preheater Voltage:
Quote No.:	Power:	Pump Serial No.:
Pump Model:	Rotation: CLOCKWISE (Right Hand)	SO No.: