

CLARKE FIRE PUMP DRIVERS
EPA NSPS TIER 3 ENGINE MODELS
HSC 8150 SERIES PUMPS

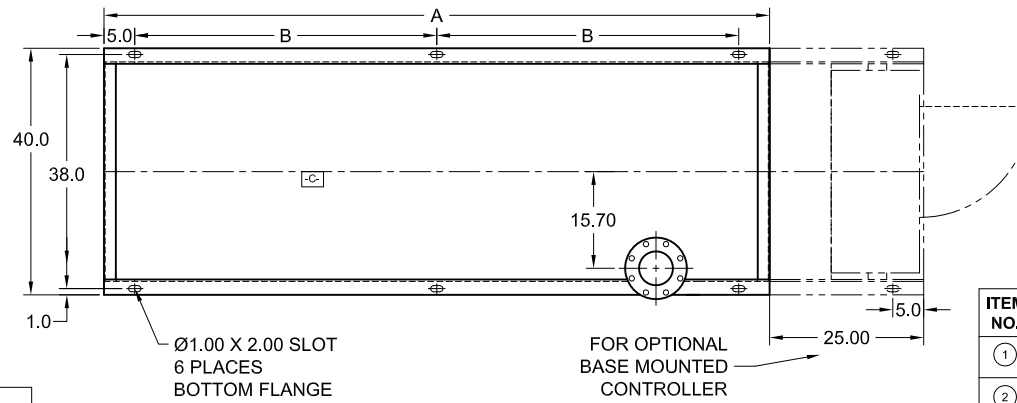

- A- - MOUNTING FACE OF FLYWHEEL
- B- - ENGINE CRANKSHAFT HORIZONTAL CENTERLINE
- C- - ENGINE CRANKSHAFT VERTICAL CENTERLINE
- D- - PUMP SHAFT HORIZONTAL CENTERLINE



| NON-LISTED DRIVESHAFTS | |
|-----------------------------|------------------|
| ENGINE MODEL | DRIVESHAFT MODEL |
| JX6H-UFADF0, 60, N0, P0, 88 | SC2160A |

| ITEM NO. | DESCRIPTION | CONNECTION SIZE |
|----------|---------------------------|---|
| ① | EXHAUST OUTLET CONNECTION | 8" 150# FLG. |
| ② | RAW WATER OUTLET | SEE NOTE 6. |
| ③ | FUEL SUPPLY CONNECTION | 3/4" NPTF |
| ④ | FUEL RETURN CONNECTION | 1/2" NPTF |
| ⑤ | HEATER JUNCTION BOX | VOLTAGE REQUIREMENTS: AC CONNECTION HEATER 2500 WATTS STD- 230 VAC ±5%-10% OPT- 115 VAC ±5%-10% |

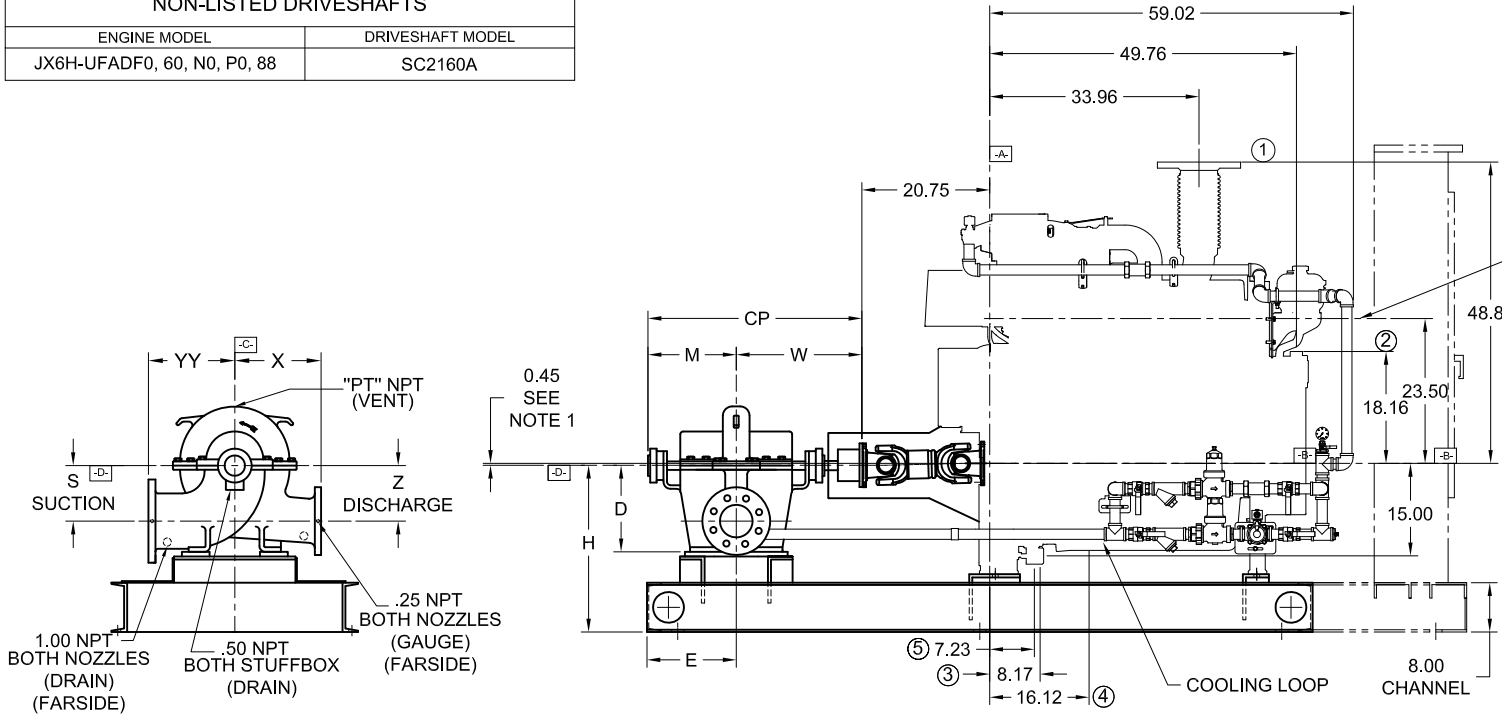

- NOTES:
1. THE DRIVE SHAFT IS DESIGNED TO OPERATE AT A 2° ANGLE WITH THE INPUT AND OUTPUT SHAFTS IN PARALLEL. THE ENGINE CRANKSHAFT IS TO BE SET WITH A PARALLEL OFFSET OF 0.45 ± 0.15 INCHES VERTICALLY ABOVE THE PUMP SHAFT AND 0.00" ± 0.15 INCH PARALLEL OFFSET HORIZONTALLY RIGHT OR LEFT OF THE PUMP SHAFT. REFER TO THE CERTIFIED DRIVESHAFT INSTRUCTIONS MANUAL FOR ALIGNMENT INSTRUCTIONS.
 2. BASE MUST BE COMPLETELY FILLED WITH GROUT PER NFPA 20.
 3. PUMP IS CW (CLOCKWISE) ROTATION WHEN VIEWED FROM THE COUPLING END.
 4. ALL DIMENSIONS ARE IN INCHES.
 5. SUCTION AND DISCHARGE FLANGES DRILLED PER ANSI B16.1 (IF APPLICABLE).
 6. RAW WATER DRAIN PIPING SIZE VARIES BASED UPON SITE CONDITIONS. ENIGNE CONN. SIZE: 1-1/2" NPT

| PUMP TYPE | PUMP SIZE | DIMENSIONS | | | | | | | | | | | | | | |
|-----------|-----------|------------|--------|----|-------|-------|-------|-------|-------|-------|-------|-------|-------|------|---|----|
| | | SUCT. | DISCH. | A | B | H | E | M | W | CP | D | YY | X | S | Z | PT |
| 16x10x22 | 16 10 | 118 | 54 | 33 | 20.19 | 24.44 | 29.81 | 54.25 | 24.00 | 29.00 | 24.00 | 14.00 | 14.00 | 1.00 | | |

| NOT FOR CONSTRUCTION, INSTALLATION OR APPLICATION PURPOSES UNLESS CERTIFIED. | | | | | | | | | |
|--|--|------|---------------|-----------|--------------------|--------------|----------|--------------|-----------|
| CERTIFIED FOR: | | | | | APPROVAL | | | | |
| CUSTOMER ORDER NO: | | | | | IDENTIFICATION NO: | | | | |
| PUMP DATA | | SIZE | MODEL | CURVE NO. | GPM | HEAD (FT.) | ROTATION | SUCTION | DISCHARGE |
| ENGINE DATA | | MAKE | MODEL | HP | RPM | VOLTAGE | POLARITY | MAX ALTITUDE | |
| SHOP ORDER: | | | CERTIFIED BY: | | | TOTAL WEIGHT | | DATE: | |
| | | | | | | | | | |
| | | | | | | | | | |
| | | | | | | | | | |
| | | | | | | | | | |