

CLARKE FIRE PUMP DRIVERS
EPA NSPS TIER 2 ENGINE MODELS
VT APPLICATIONS

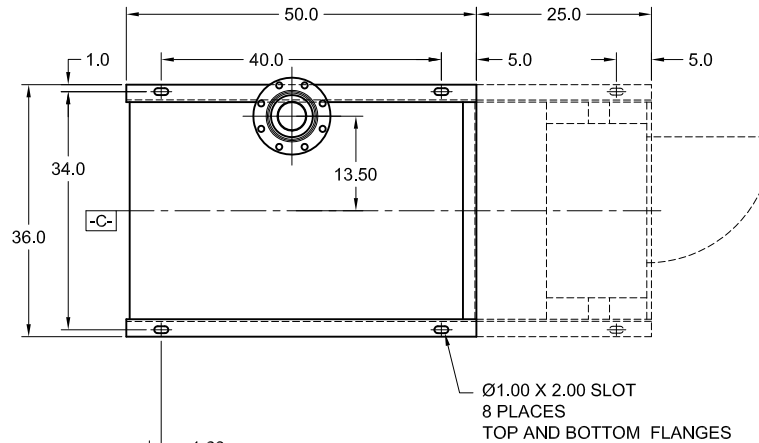

- A- - MOUNTING FACE OF FLYWHEEL
- B- - ENGINE CRANKSHAFT HORIZONTAL CENTERLINE
- C- - ENGINE CRANKSHAFT VERTICAL CENTERLINE
- D- - RIGHT ANGLE GEAR SHAFT CENTERLINE



LISTED DRIVESHAFT				
ENGINE MODEL	DRIVESHAFT MODEL	DIM: G	DIM: J	DIM: K
ZF6H-UFAC60, AC70	CDS50-SC*	19.75	0.45	0.11

*1470, 1760 & 2100 RPM ONLY

NON-LISTED DRIVESHAFT	
ENGINE MODEL	DRIVESHAFT MODEL
ZF6H-UFAC60, AC70	SC81A**

**2350 & 2650 RPM ONLY

DRIVESHAFT MODEL	COUPLING MODEL	DIM: A
CDS50-SC	TC45-11.5-81-FS	24.49

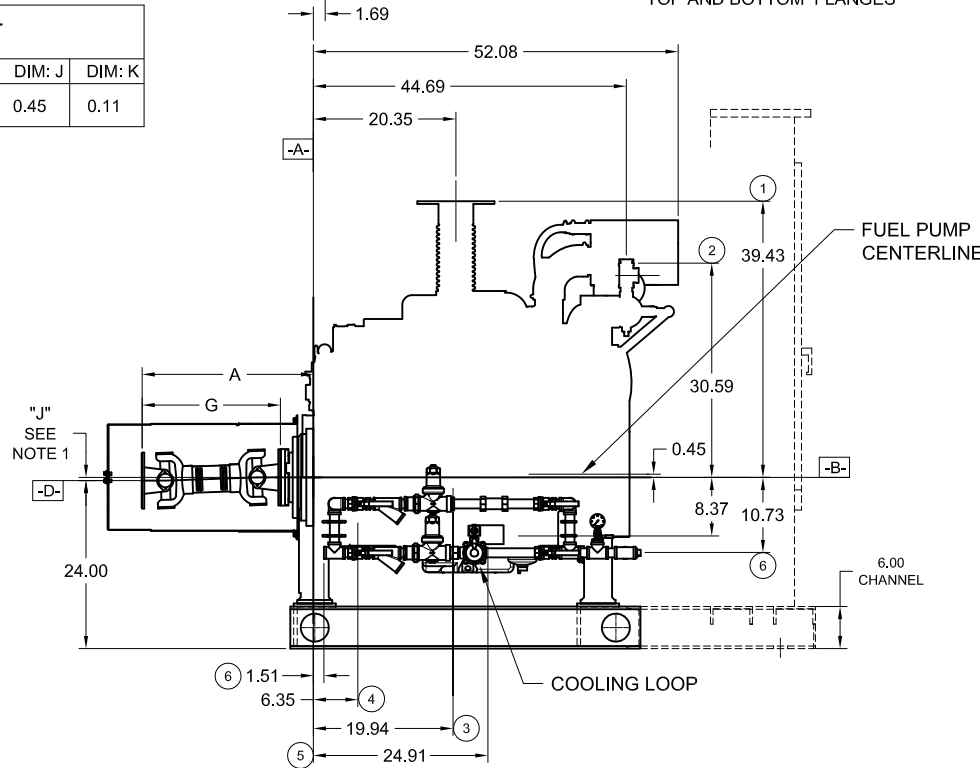

ITEM NO.	DESCRIPTION	CONNECTION SIZE
①	EXHAUST OUTLET CONNECTION	6" 150# FLG EXHAUST
②	RAW WATER OUTLET	SEE NOTE 6
③	FUEL SUPPLY CONNECTION (FAR SIDE)	1/2" NPTF
④	FUEL RETURN CONNECTION (FAR SIDE)	3/8" NPTF
⑤	HEATER JUNCTION BOX	VOLTAGE REQUIREMENTS: AC CONNECTION HEATER 2000 WATTS STD- 115 VAC ±5%-10% OPT- 230 VAC ±5%-10%
⑥	RAW WATER INLET	SEE NOTE 7

NOTES:

1. THE DRIVE SHAFT IS DESIGNED TO OPERATE AT A 2° ANGLE WITH THE INPUT AND OUTPUT SHAFTS IN PARALLEL. THE ENGINE CRANKSHAFT IS TO BE SET WITH A PARALLEL OFFSET OF "J" ± "K" INCHES VERTICALLY ABOVE THE PUMP SHAFT AND 0.00" ±"K" INCH PARALLEL OFFSET HORIZONTALLY RIGHT OR LEFT OF THE PUMP SHAFT. REFER TO THE CERTIFIED DRIVESHAFT INSTRUCTIONS MANUAL FOR ALIGNMENT INSTRUCTIONS.
2. BASE MUST BE COMPLETELY FILLED WITH GROUT PER NFPA 20.
3. ENGINE IS CW (CLOCKWISE) ROTATION WHEN VIEWED FROM THE HEAT EXCHANGER / FRONT OF ENGINE.
4. ALL DIMENSIONS ARE IN INCHES.
5. SUCTION AND DISCHARGE FLANGES DRILLED PER ANSI B16.1. (IF APPLICABLE)
6. RAW WATER OUTLET SIZE VARIES BASED UPON SITE CONDITIONS. DEFAULT SIZE: 1-1/4" NPT
7. RAW WATER INLET SIZE VARIES BASED UPON SITE CONDITIONS.

NOT FOR CONSTRUCTION, INSTALLATION OR APPLICATION PURPOSES UNLESS CERTIFIED.								
CERTIFIED FOR:							APPROVAL <input type="checkbox"/> UL <input type="checkbox"/> FM <input type="checkbox"/> ULC	
CUSTOMER ORDER NO:				IDENTIFICATION NO:			FLANGES	
PUMP DATA	SIZE	MODEL	CURVE NO.	GPM	HEAD (FT.)	ROTATION	SUCTION	DISCHARGE
						CW		
ENGINE DATA	MAKE	MODEL	HP	RPM	VOLTAGE	POLARITY	MAX ALTITUDE	
	CLARKE					NEG.		
SHOP ORDER:			CERTIFIED BY:			TOTAL WEIGHT		DATE: