

CLARKE FIRE PUMP DRIVERS
EPA NSPS TIER 1 ENGINE MODELS
HSC 8100 SERIES PUMPS

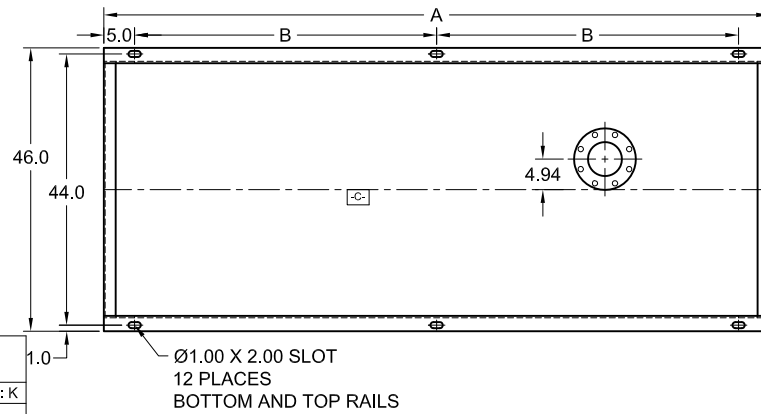

- A- - MOUNTING FACE OF FLYWHEEL
- B- - ENGINE CRANKSHAFT HORIZONTAL CENTERLINE
- C- - ENGINE CRANKSHAFT VERTICAL CENTERLINE
- D- - PUMP SHAFT HORIZONTAL CENTERLINE



UL LISTED DRIVESHAFTS				
ENGINE MODEL	DRIVESHAFT MODEL	DIM: G	DIM: J	DIM: K
JU6R-UFAA59, 61, 83	CDS30-S1	15.75	0.35	0.10
JU6R-UFAAPP, RF, Q7, S9	CDS50-SC	20.38	0.45	0.11

ITEM NO.	DESCRIPTION	CONNECTION SIZE
①	EXHAUST OUTLET CONNECTION	5" 150# FLANGE
②	FUEL SUPPLY CONNECTION	1/2" NPTF
③	FUEL RETURN CONNECTION	3/8" NPTF
④	HEATER JUNCTION BOX	VOLTAGE REQUIREMENTS: AC CONNECTION HEATER 1360 WATTS STD- 115 VAC ±5%-10% OPT- 230 VAC ±5%-10%

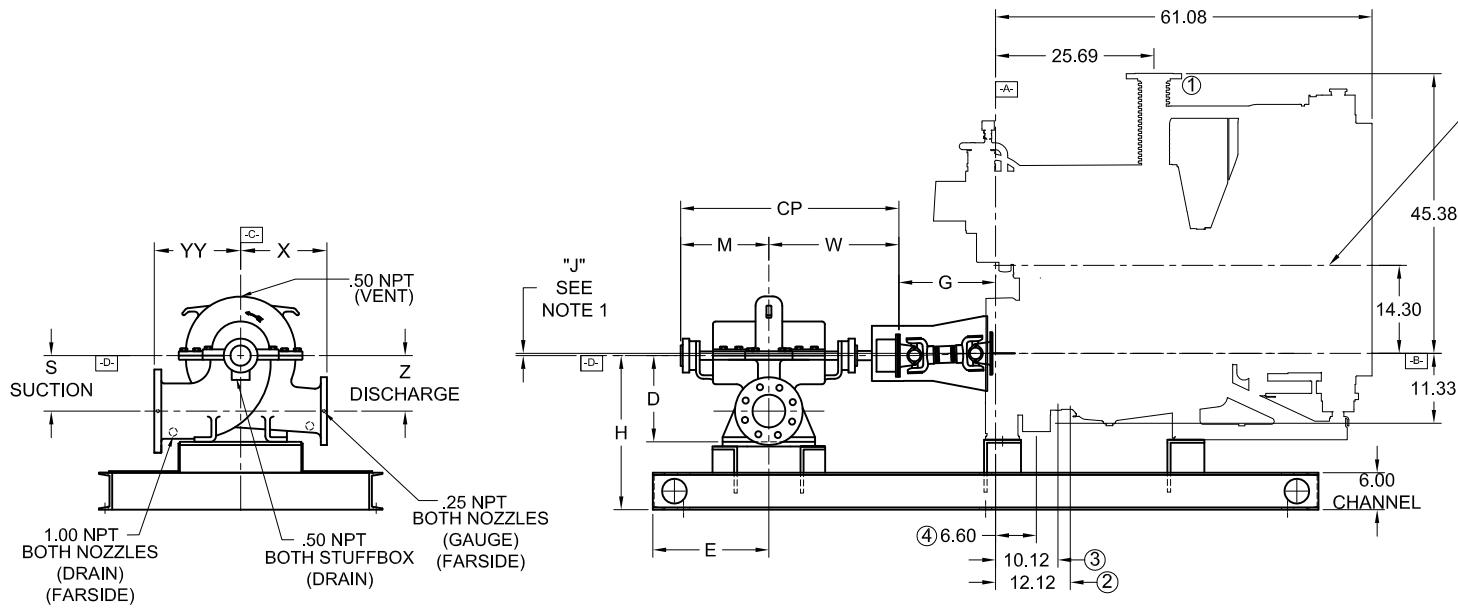

FUEL PUMP CENTERLINE

NOTES:

- THE DRIVE SHAFT IS DESIGNED TO OPERATE AT A 2° ANGLE WITH THE INPUT AND OUTPUT SHAFTS IN PARALLEL. THE ENGINE CRANKSHAFT IS TO BE SET WITH A PARALLEL OFFSET OF "J" ± "K" INCHES VERTICALLY ABOVE THE PUMP SHAFT AND 0.00" ± "K" INCHES PARALLEL OFFSET HORIZONTALLY RIGHT OR LEFT OF THE PUMP SHAFT. REFER TO THE CERTIFIED DRIVESHAFT INSTRUCTIONS MANUAL FOR ALIGNMENT INSTRUCTIONS.
- BASE MUST BE COMPLETELY FILLED WITH GROUT PER NFPA 20.
- PUMP IS CW (CLOCKWISE) ROTATION WHEN VIEWED FROM THE COUPLING END.
- ALL DIMENSIONS ARE IN INCHES.
- SUCTION AND DISCHARGE FLANGES DRILLED PER ANSI B16.1 (IF APPLICABLE).

PUMP TYPE	PUMP SIZE		DIMENSIONS											
	SUCT.	DISCH.	A	B	H	E	M	W	CP	D	YY	X	S	Z
6x4x12 F	6	4	108	49	21	12.50	13.25	17.50	30.75	12.00	13.00	11.50	7.80	7.80
8x6x12 F-M	8	6	108	49	24	11.50	14.62	18.50	33.12	14.00	14.00	14.00	9.00	9.00
8x6x18 F	8	6	118	54	24	18.75	15.62	21.25	36.87	14.00	16.00	14.00	9.00	9.00
8x8x12 F	8	8	118	54	23	18.75	15.62	21.25	36.87	12.75	16.50	14.00	8.00	8.00
10x8x17 F	10	8	88	39	26	17.44	17.00	22.56	39.56	16.00	18.00	16.00	10.00	10.00
10x8x20 F	10	8	118	54	30	17.44	17.00	22.56	39.56	20.00	20.00	18.00	14.00	14.00
12x10x18 F	12	10	118	54	29	17.44	17.00	22.56	39.56	18.00	20.00	18.00	11.00	11.00

NOT FOR CONSTRUCTION, INSTALLATION OR APPLICATION PURPOSES UNLESS CERTIFIED.									
CERTIFIED FOR:							APPROVAL		
CUSTOMER ORDER NO:							IDENTIFICATION NO:		
PUMP DATA		SIZE	MODEL	CURVE NO.	GPM	HEAD (FT.)	ROTATION	SUCTION	DISCHARGE
ENGINE DATA		MAKE	MODEL	HP	RPM	VOLTAGE	POLARITY	MAX ALTITUDE	
SHOP ORDER:				CERTIFIED BY:			TOTAL WEIGHT		DATE:
							UL FM ULC		
						CW			
		CLARKE				NEG.			