

CLARKE FIRE PUMP DRIVERS
NON-EMISSION ENGINE MODELS
HSC 8200 SERIES PUMPS

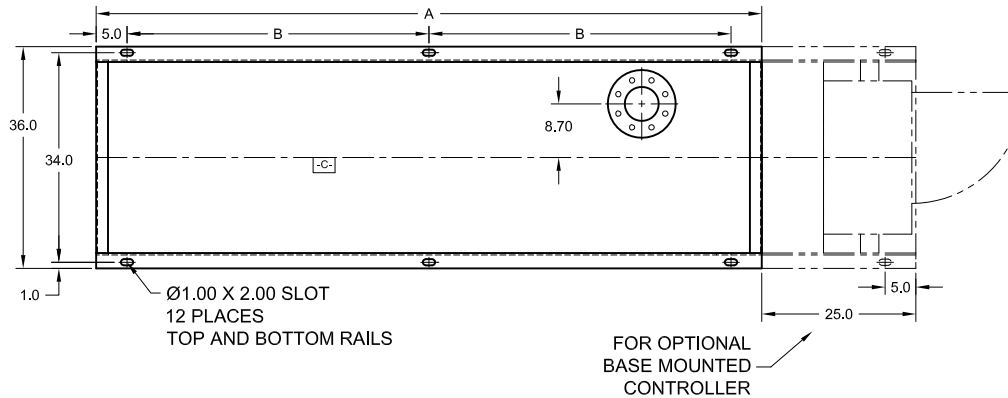

- A- - MOUNTING FACE OF FLYWHEEL
- B- - ENGINE CRANKSHAFT HORIZONTAL CENTERLINE
- C- - ENGINE CRANKSHAFT VERTICAL CENTERLINE
- D- - PUMP SHAFT HORIZONTAL CENTERLINE



UL LISTED DRIVESHAFT	
ENGINE MODEL	DRIVESHAFT MODEL
DQ6H-UFAA50, 60, 88, 98	CDS50-SC

ITEM NO.	DESCRIPTION	CONNECTION SIZE
①	EXHAUST OUTLET CONNECTION	6" 150# FLG.
②	RAW WATER OUTLET	SEE NOTE 6.
③	FUEL SUPPLY CONNECTION	1/2" NPTF
④	FUEL RETURN CONNECTION	3/8" NPTF
⑤	HEATER JUNCTION BOX	VOLTAGE REQUIREMENTS: AC CONNECTION HEATER 2000 WATTS STD- 230 VAC ±5%-10% OPT- 115 VAC ±5%-10%

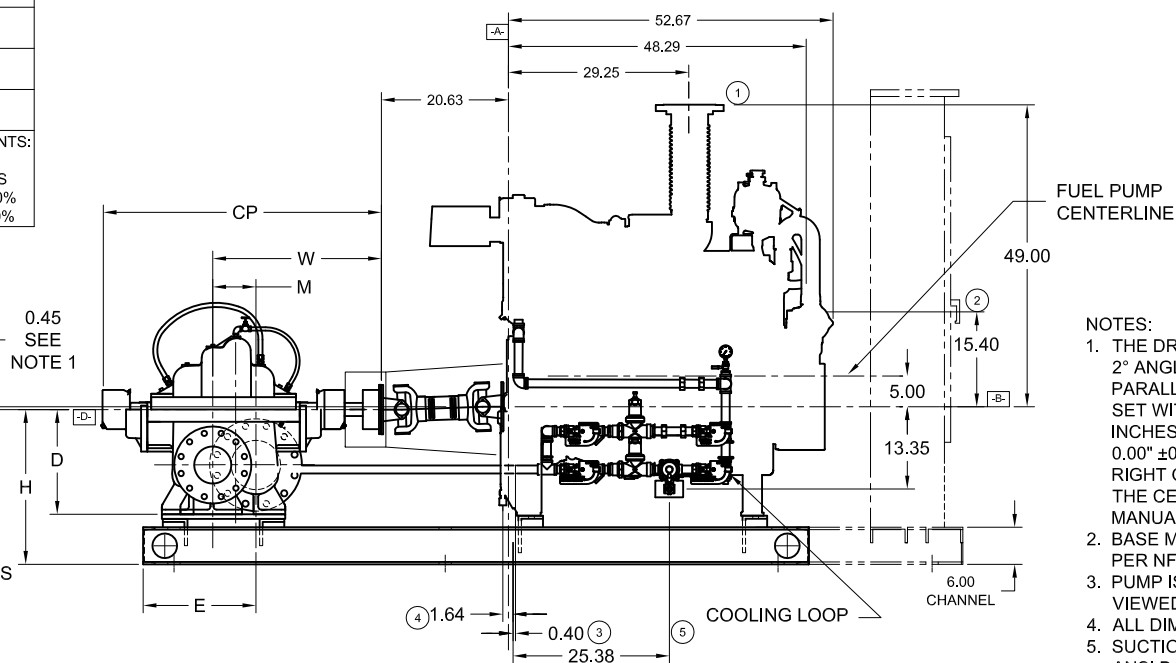
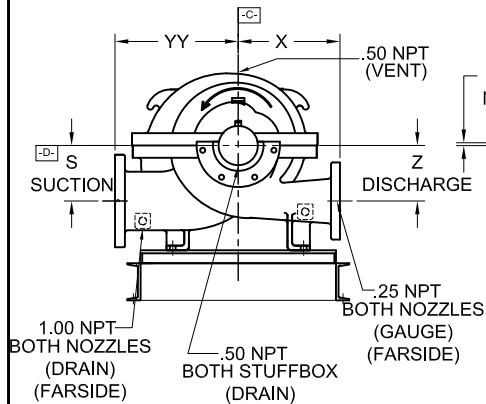

NOTES:

1. THE DRIVE SHAFT IS DESIGNED TO OPERATE AT A 2° ANGLE WITH THE INPUT AND OUTPUT SHAFTS IN PARALLEL. THE ENGINE CRANKSHAFT IS TO BE SET WITH A PARALLEL OFFSET OF 0.45 ±0.11 INCHES VERTICALLY ABOVE THE PUMP SHAFT AND 0.00" ±0.11 INCH PARALLEL OFFSET HORIZONTALLY RIGHT OR LEFT OF THE PUMP SHAFT. REFER TO THE CERTIFIED DRIVESHAFT INSTRUCTIONS MANUAL FOR ALIGNMENT INSTRUCTIONS.
2. BASE MUST BE COMPLETELY FILLED WITH GROUT PER NFPA 20.
3. PUMP IS CW (CLOCKWISE) ROTATION WHEN VIEWED FROM THE COUPLING END.
4. ALL DIMENSIONS ARE IN INCHES.
5. SUCTION AND DISCHARGE FLANGES DRILLED PER ANSI B16.1 (IF APPLICABLE).
6. RAW WATER DRAIN PIPING SIZE VARIES BASED UPON SITE CONDITIONS. ENGINE CONN. SIZE: 1-1/4" NPT.

PUMP TYPE	PUMP SIZE		DIMENSIONS											
	SUCT.	DISCH.	A	B	H	E	M	W	CP	D	YY	X	S	Z
8X6X18F	8	6	118	54	26	29.12	7.00	27.88	45.54	19.00	20.00	16.50	11.00	11.00

NOT FOR CONSTRUCTION, INSTALLATION OR APPLICATION PURPOSES UNLESS CERTIFIED.							
CERTIFIED FOR:						APPROVAL	
CUSTOMER ORDER NO:						IDENTIFICATION NO:	
PUMP DATA		SIZE	MODEL	CURVE NO.	GPM	HEAD (FT.)	ROTATION
ENGINE DATA		MAKE	MODEL	HP	RPM	VOLTAGE	POLARITY
SHOP ORDER:		CERTIFIED BY:			TOTAL WEIGHT		DATE: