

JOB: UNIT TAG: ENGINEER: CONTRACTOR:	REPRESENTATIVE: ORDER NO. SUBMITTED BY: APPROVED BY:	DATE: DATE: DATE:
---	---	--

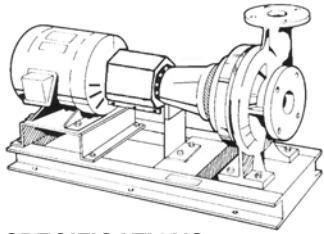

4BC

Series 1510

Centrifugal Pumps - Base Mounted

SPECIFICATIONS

FLOW _____ HEAD _____
 HP _____ RPM _____
 VOLTS _____
 CYCLE _____ PHASE _____
 ENCLOSURE _____
 APPROX. WEIGHT _____
 SPECIALS _____

MATERIALS OF CONSTRUCTION

BRONZE FITTED ALL IRON

FEATURES

- i-ALERT™ Condition Monitor
- ANSI/OSHA Coupling Guard
- Center Drop Out Spacer Coupling
- Fabricated Heavy Duty Baseplate

MAXIMUM WORKING PRESSURE

- 175 psi (12 bar) W.P.
w/ 125# ANSI flange drilling

TYPE OF SEAL

- 1510 Standard Seal (Buna-Carbon/Ceramic)
- 1510 -F Standard Seal w/ Flush Line (Buna-Carbon/Ceramic)
- 1510 -S Stuffing Box construction w/ Flushed Mechanical Single Seal (EPR-Tungsten Carbide/Carbon)
- 1510 -D Stuffing Box construction w/ Flushed Double Mechanical Seal (EPR-Carbon/Ceramic) Requires external water source
- 1510 -PF Stuffing Box Construction w/ Packing (Graphite Impregnated Teflon)

Note: Equipped with NEOPRENE coupling

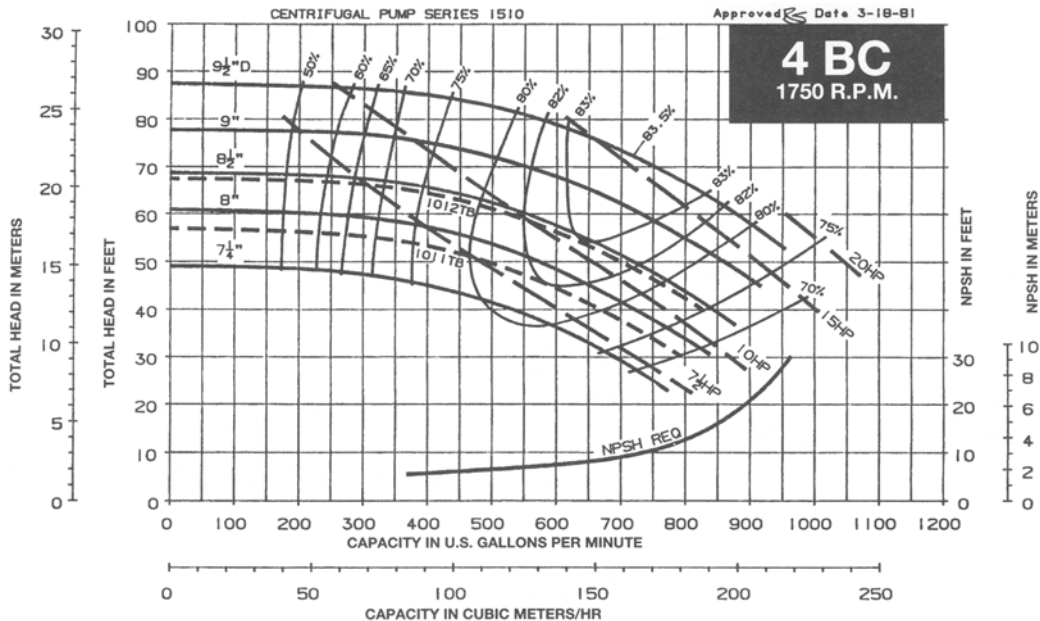

JOB: UNIT TAG: ENGINEER: CONTRACTOR:	REPRESENTATIVE: ORDER NO. SUBMITTED BY: APPROVED BY:	DATE: DATE: DATE:
---	---	--

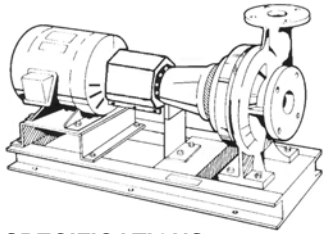

4BC

Series 1510

Centrifugal Pumps - Base Mounted

SPECIFICATIONS

FLOW _____ HEAD _____
 HP _____ RPM _____
 VOLTS _____
 CYCLE _____ PHASE _____
 ENCLOSURE _____
 APPROX. WEIGHT _____
 SPECIALS _____

MATERIALS OF CONSTRUCTION

BRONZE FITTED ALL IRON

FEATURES

- i-ALERT™ Condition Monitor
- ANSI/OSHA Coupling Guard
- Center Drop Out Spacer Coupling
- Fabricated Heavy Duty Baseplate

MAXIMUM WORKING PRESSURE

- 175 psi (12 bar) W.P.
w/ 125# ANSI flange drilling

TYPE OF SEAL

- 1510 Standard Seal (Buna-Carbon/Ceramic)
- 1510 -F Standard Seal w/ Flush Line (Buna-Carbon/Ceramic)
- 1510 -S Stuffing Box construction w/ Flushed Mechanical Single Seal (EPR-Tungsten Carbide/Carbon)
- 1510 -D Stuffing Box construction w/ Flushed Double Mechanical Seal (EPR-Carbon/Ceramic) Requires external water source
- 1510 -PF Stuffing Box Construction w/ Packing (Graphite Impregnated Teflon)

Note: Equipped with NEOPRENE coupling

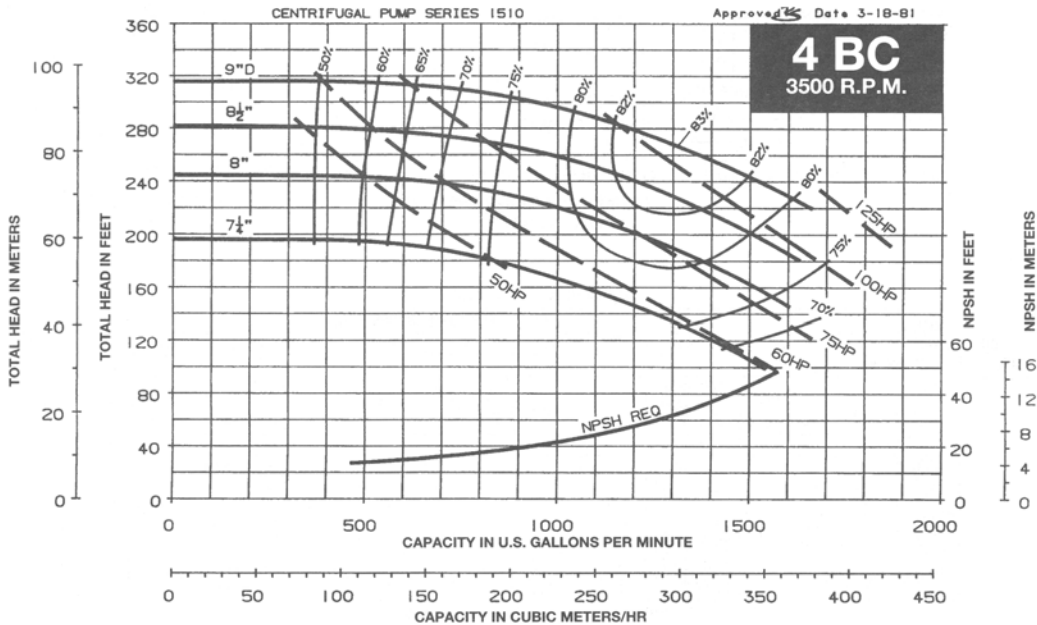

Series 1510 4BC Centrifugal Pump Submittal

B-225.1H

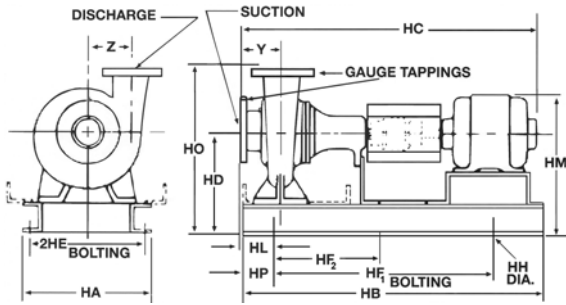

FLANGE DIMENSIONS IN INCHES (MM)			
	SIZE	THICKNESS	O.D.
Discharge	4" (102)	1-1/4" (32)	9-1/2" (241)
Suction	5" (127)	1-3/8" (35)	10-3/4" (273)

FLANGES ARE 125# ANSI - STANDARD

DIMENSIONS - Inches (mm) STANDARD SEAL 1510, 1510-F

MOTOR FRAME	HA	HB	HC MAX	HD	2HE	HF ₁	HF ₂	HH	HL	HM MAX	HO	HP	Y	Z
"S" FRAME														
213T	14-5/8 (371)	34-5/8 (879)	37-3/4 (959)	12-3/4 (324)	12-7/8 (327)	28-5/8 (727)	-	3/4 (19)	4 (102)	18-5/8 (473)	20-3/4 (527)	3 (76)	5 (127)	7 (178)
215T	14-5/8 (371)	34-5/8 (879)	39-1/4 (997)	12-3/4 (324)	12-7/8 (327)	28-5/8 (727)	-	3/4 (19)	4 (102)	18-5/8 (473)	20-3/4 (527)	3 (76)	5 (127)	7 (178)
254T	14-5/8 (371)	39-3/8 (1000)	43 (1092)	12-3/4 (324)	12-7/8 (327)	33-3/8 (848)	-	3/4 (19)	4 (102)	19-5/8 (498)	20-3/4 (527)	3 (76)	5 (127)	7 (178)
"L" FRAME														
256T	16 (406)	46-1/2 (1181)	49-1/8 (1248)	14 (356)	14 (356)	36-1/2 (927)	18-1/4 (464)	7/8 (22)	5-1/8 (130)	20-7/8 (530)	22 (559)	5 (127)	5 (127)	7 (178)
284TS	16 (406)	46-1/2 (1181)	48-1/2 (1232)	14 (356)	14 (356)	36-1/2 (927)	18-1/4 (464)	7/8 (22)	5-1/8 (130)	22 (559)	22 (559)	5 (127)	5 (127)	7 (178)
286TS	16 (406)	46-1/2 (1181)	50 (1270)	14 (356)	14 (356)	36-1/2 (927)	18-1/4 (464)	7/8 (22)	5-1/8 (130)	22 (559)	22 (559)	5 (127)	5 (127)	7 (178)
324TS	16 (406)	51-3/4 (1314)	51-7/8 (1318)	14 (356)	14 (356)	41-3/4 (1060)	20-7/8 (530)	7/8 (22)	5-1/8 (130)	23-1/8 (587)	22 (559)	5 (127)	5 (127)	7 (178)
326TS	16 (406)	51-3/4 (1314)	53-5/8 (1362)	14 (356)	14 (356)	41-3/4 (1060)	20-7/8 (530)	7/8 (22)	5-1/8 (130)	23-1/8 (587)	22 (559)	5 (127)	5 (127)	7 (178)
364TS	24 (610)	56 (1422)	55-1/4 (1403)	16-1/2 (419)	21-1/2 (546)	44 (1118)	22 (559)	1 (25)	5-3/4 (146)	26-3/4 (679)	24-1/2 (622)	6 (152)	5 (127)	7 (178)
365TS	24 (610)	56 (1422)	55-7/8 (1419)	16-1/2 (419)	21-1/2 (546)	44 (1118)	22 (559)	1 (25)	5-3/4 (146)	26-3/4 (679)	24-1/2 (622)	6 (152)	5 (127)	7 (178)
404TS	24 (610)	56 (1422)	58-1/8 (1476)	16-1/2 (419)	21-1/2 (546)	44 (1118)	22 (559)	1 (25)	5-3/4 (146)	28-3/8 (721)	24-1/2 (622)	6 (152)	5 (127)	7 (178)
405TS	24 (610)	56 (1422)	58-7/8 (1496)	16-1/2 (419)	21-1/2 (546)	44 (1118)	22 (559)	1 (25)	5-3/4 (146)	30 (762)	24-1/2 (622)	6 (152)	5 (127)	7 (178)

STUFFING BOX 1510-PF, 1510-S, 1510-D

MOTOR FRAME	HA	HB	HC MAX	HD	2HE	HF ₁	HF ₂	HH	HL	HM MAX	HO	HP	Y	Z
"L" FRAME														
213T	16 (406)	46-1/2 (1181)	44-1/2 (1130)	14 (356)	14 (356)	36-1/2 (927)	18-1/4 (464)	7/8 (22)	5-1/8 (130)	19-7/8 (505)	22 (559)	5 (127)	5 (127)	7 (178)
215T	16 (406)	46-1/2 (1181)	46 (1168)	14 (356)	14 (356)	36-1/2 (927)	18-1/4 (464)	7/8 (22)	5-1/8 (130)	19-7/8 (505)	22 (559)	5 (127)	5 (127)	7 (178)
254T	16 (406)	51-3/4 (1314)	49-3/4 (1264)	14 (356)	14 (356)	41-3/4 (1060)	20-7/8 (530)	7/8 (22)	5-1/8 (130)	20-7/8 (530)	22 (559)	5 (127)	5 (127)	7 (178)
256T	16 (406)	51-3/4 (1314)	51-1/2 (1308)	14 (356)	14 (356)	41-3/4 (1060)	20-7/8 (530)	7/8 (22)	5-1/8 (130)	20-7/8 (530)	22 (559)	5 (127)	5 (127)	7 (178)

Dimensions are subject to change. Not to be used for construction purposes unless certified.
Box type pumps should not be operated at 3500 RPM.

Xylem Inc.
8200 N. Austin Avenue
Morton Grove, IL 60053
Phone: (847)966-3700
Fax: (847)965-8379
www.xyleminc.com/brands/bellgossett



Bell & Gossett is a trademark of Xylem Inc. or one of its subsidiaries.
© 2012 Xylem Inc.