

CLARKE FIRE PUMP DRIVERS  
EPA NSPS TIER 3 ENGINE MODELS  
VT APPLICATIONS



a xylem brand

Vertical Pumps

- A- - MOUNTING FACE OF FLYWHEEL
- B- - ENGINE CRANKSHAFT HORIZONTAL CENTERLINE
- C- - ENGINE CRANKSHAFT VERTICAL CENTERLINE
- D- - RIGHT ANGLE GEAR SHAFT CENTERLINE

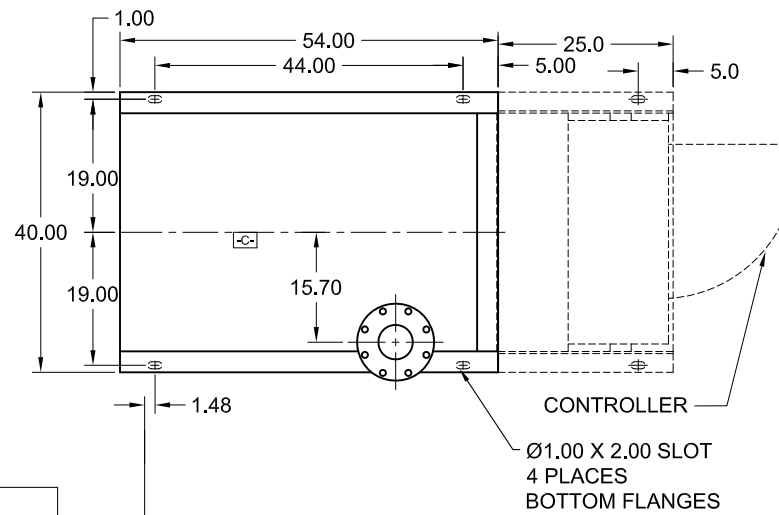

NON-LISTED DRIVESHAFTS

ENGINE MODEL	DRIVESHAFT MODEL	COUPLING MODEL	DIM: A
JX6H-UFAD60, 88, F0, K0°, N0, P0	SC2160A	TC55-14-180.10 FS	24.87

\* INDICATES PLD ENGINE MODEL ONLY

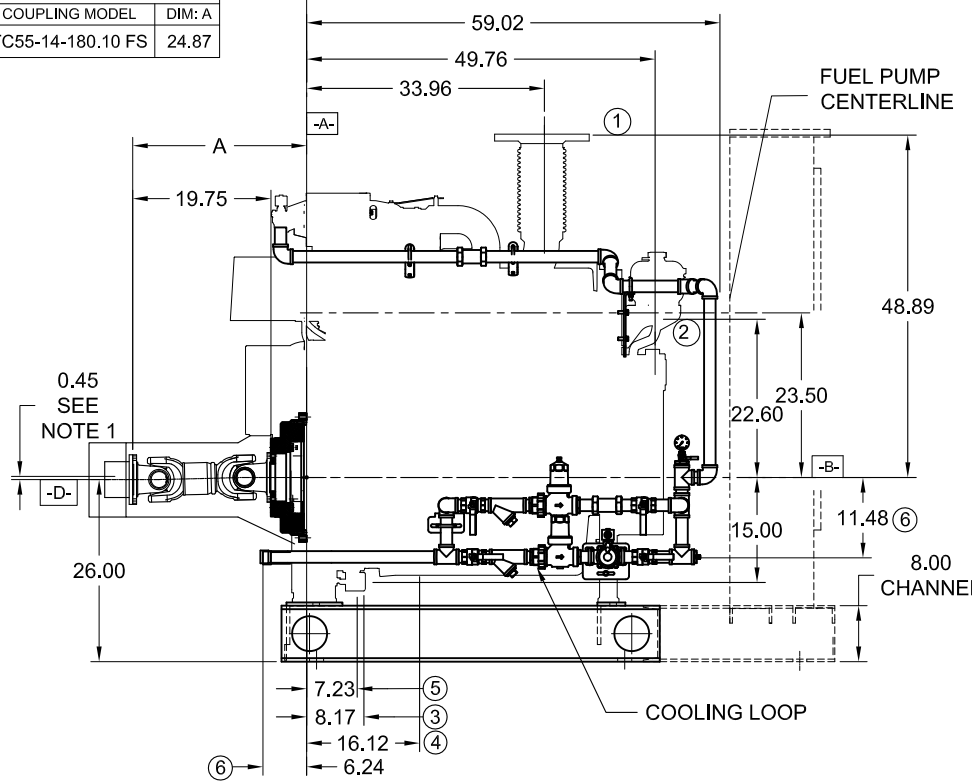

ITEM NO.	DESCRIPTION	CONNECTION SIZE
1	EXHAUST OUTLET CONNECTION	8" 150# FLG.
2	RAW WATER OUTLET	SEE NOTE 6.
3	FUEL SUPPLY CONNECTION	3/4" NPTF
4	FUEL RETURN CONNECTION	1/2" NPTF
5	HEATER JUNCTION BOX	VOLTAGE REQUIREMENTS: AC CONNECTION HEATER 2500 WATTS STD- 230 VAC ±5%-10% OPT- 115 VAC ±5%-10%
6	RAW WATER INLET	SEE NOTE 7.

NOTES:

1. THE DRIVE SHAFT IS DESIGNED TO OPERATE AT A 2° ANGLE WITH THE INPUT AND OUTPUT SHAFTS IN PARALLEL. THE ENGINE CRANKSHAFT IS TO BE SET WITH A PARALLEL OFFSET OF 0.45 ± 0.15 INCHES VERTICALLY ABOVE THE PUMP SHAFT AND 0.00" ± 0.15 INCH PARALLEL OFFSET HORIZONTALLY RIGHT OR LEFT OF THE PUMP SHAFT. REFER TO THE CERTIFIED DRIVESHAFT INSTRUCTIONS MANUAL FOR ALIGNMENT INSTRUCTIONS.
2. BASE MUST BE COMPLETELY FILLED WITH GROUT PER NFPA 20.
3. ENGINE IS CW (CLOCKWISE) ROTATION WHEN VIEWED FROM THE HEAT EXCHANGER/FRONT.
4. ALL DIMENSIONS ARE IN INCHES.
5. SUCTION AND DISCHARGE FLANGES DRILLED PER ANSI B16.1 (IF APPLICABLE).
6. RAW WATER OUTLET SIZE VARIES BASED UPON SITE CONDITIONS. DEFAULT SIZE: 1-1/2" NPT.
7. RAW WATER INLET SIZE VARIES BASED ON SITE CONDITIONS.

NOT FOR CONSTRUCTION, INSTALLATION OR APPLICATION PURPOSES UNLESS CERTIFIED.

CERTIFIED FOR:							APPROVAL <input type="checkbox"/> UL <input type="checkbox"/> FM <input type="checkbox"/> ULC	
CUSTOMER ORDER NO:				IDENTIFICATION NO:			FLANGES	
PUMP DATA	SIZE	MODEL	CURVE NO.	GPM	HEAD (FT.)	ROTATION	SUCTION	DISCHARGE
						CW		
ENGINE DATA	MAKE	MODEL	HP	RPM	VOLTAGE	POLARITY	MAX ALTITUDE	
	CLARKE					NEG.		
SHOP ORDER:			CERTIFIED BY:			TOTAL WEIGHT		DATE:

C132398 RevF  
13AUG15