



SC

SUBMERSIBLE SUMP/EFFLUENT PUMP



Bell & Gossett

a xylem brand

FEATURES

- Corrosion-resistant construction
- Cast iron body
- Thermoplastic impeller and cover
- Replaceable power cord
- Bearings: Upper sleeve and lower heavy duty ball bearing construction.
- Built-In Vent Hole: Prevents air-binding with no added labor.
- Motor is permanently lubricated for extended service life and is powered for continuous operation. All ratings are within the working limits of the motor.
- Complete unit is heavy duty, portable and compact.
- **Mechanical Seal:** carbon/ceramic/Buna/stainless steel.
- Stainless steel fasteners and stainless steel pipe plug.

APPLICATIONS

Specially designed for the following uses:

- Basement draining
- Water transfer
- Dewatering
- Effluent Transfer

SPECIFICATIONS

Pump:

- Discharge size: 1½" NPT
- Capacities: to 50 GPM.
- Maximum head: to 26 feet
- Temperature: 104°F (40°C) maximum, continuous when completely submerged
- Solids handling: ½" maximum sphere
- Automatic models include a float switch
- Manual model available
- Pumping range: see performance chart on back or curve below

AGENCY LISTINGS



Tested to UL 778 and CSA 22.2 108 Standards
By Canadian Standards Association
File #218526

PERFORMANCE RATINGS

SC03

Total Head (feet of water)	GPM	GPH
4	50	3,000
10	40	2,340
15	28	1,680
20	15	900

MOTOR

- SC0311: ⅓ HP, 115 V, 60 Hz, single phase, 3000 RPM, 12.0 amps maximum.
- Built-in thermal overload protection with automatic reset.
- Class B insulation
- Oil filled design
- High strength carbon steel shaft
- Power cord: Quick disconnect 10 foot standard length, heavy duty 16/3 SJTW with NEMA 5-15 P three prong grounding plug, 115V.

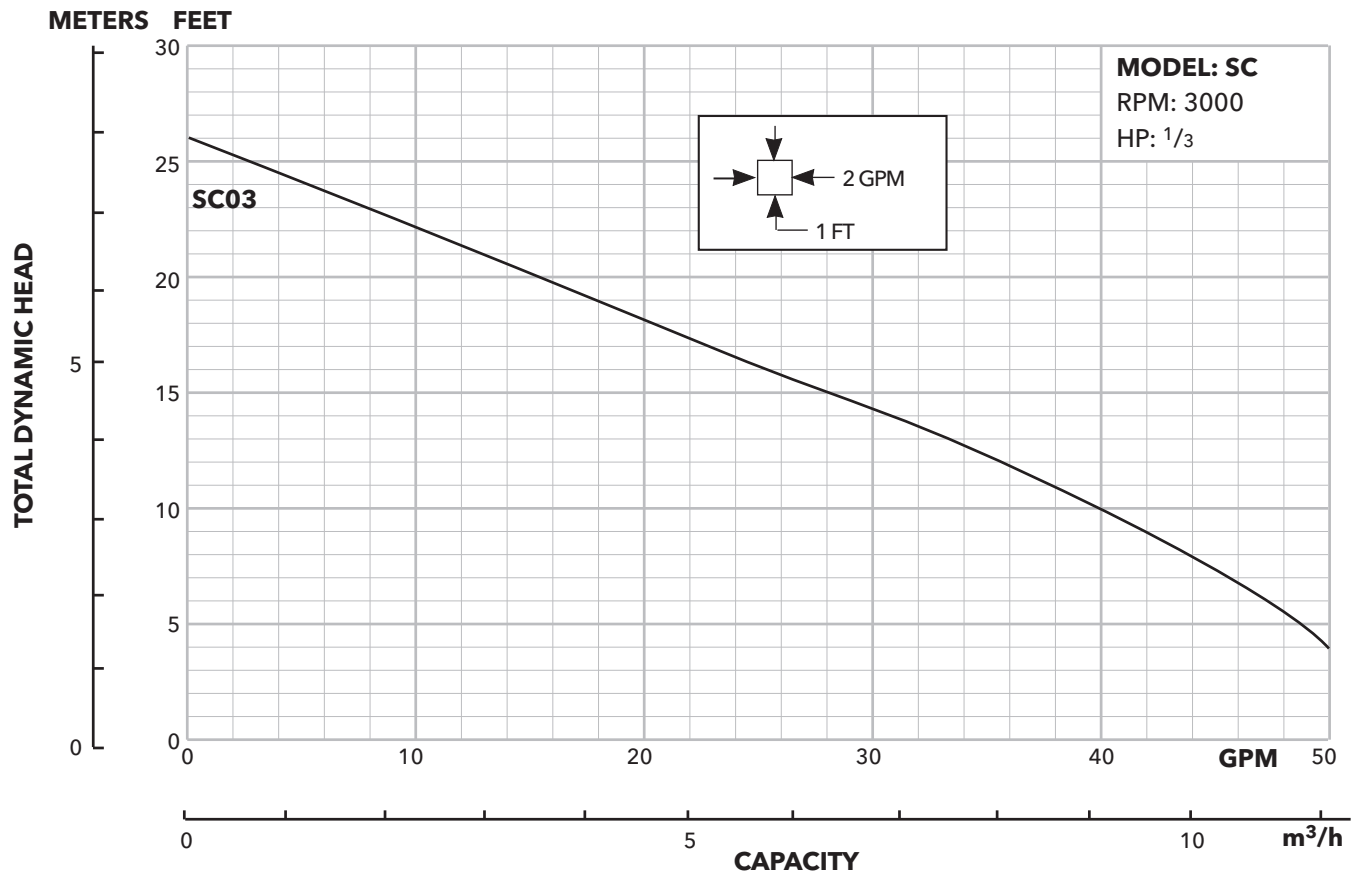

MODEL INFORMATION

Order No.	HP	Volts	Amps	Minimum Circuit Breaker	Phase	Float Switch Style	Cord Length	Discharge Connection	Minimum On Level	Minimum Off Level	Minimum Basin Diameter	Maximum Solids Size	Shipping Weight lbs/kg
SC0311AV	1/3	115	12.0	20	1	Built-In Vertical	10'	1 1/2"	8"	3.5"	11"	1/2"	29 / 13.2
SC0311P1						Piggyback Wide Angle			14"	7"	18"		
SC0311PV						Piggyback Vertical			8"	3.5"	11"		

TYPICAL SPECIFICATIONS

The contractor shall furnish and install Quantity _____, Model SC _____ submersible sump pumps as illustrated on the plans and in accordance with the following specifications.

The submersible sump pumps shall be single-phase, 115V. The power cord shall be 16/3 SJTW with a NEMA 5-15P three prong grounding plug.

The oil-filled, shaded pole motor shall have Class B insulation, automatic reset on-winding overload protection, a carbon steel shaft, upper sleeve and lower ball bearings and be protected from water intrusion by a carbon/ceramic/ BUNA/SS mechanical shaft seal. Maximum fluid temperature is 104° F (40° C) for continuous operation when pump is fully submerged.

Automatic models will be equipped with either a built-in vertical, tethered wide angle or piggyback wide angle float switch. Manual models are also available.

Pumps shall be designed to pass 1/2" maximum spheres and are suitable for basement draining, water transfer, dewatering and effluent transfer.

Materials of Construction are ASTM A48, Class 30 grey cast iron and glass-filled engineered thermoplastics.

DIMENSIONS

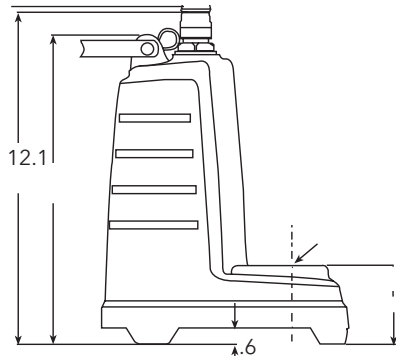
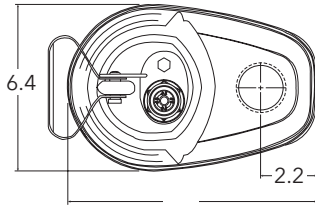

VERTICAL FLOAT SWITCH

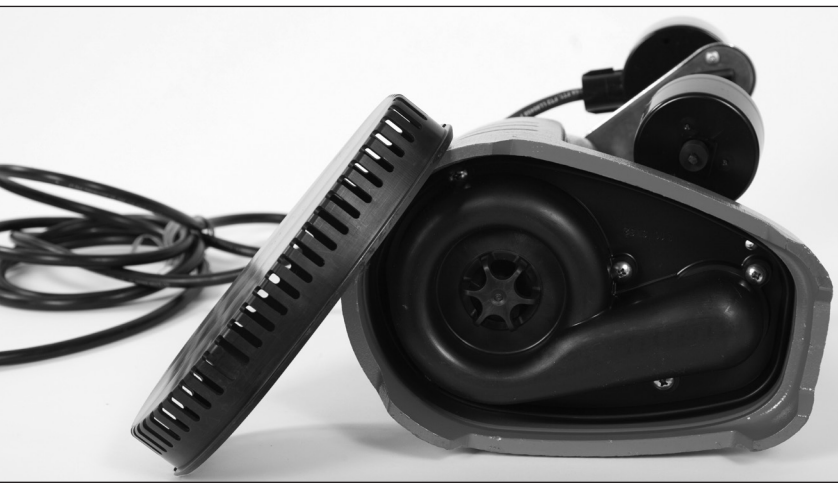
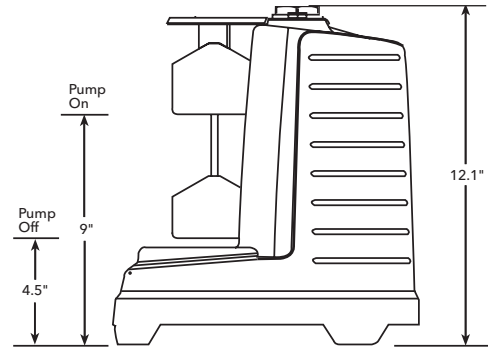
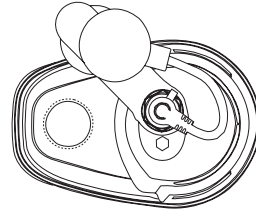

ADDITIONAL STRAINER AVAILABLE AS ACCESSORY

Part No. A2-STST

- Material of construction mineral filled TPO
- Snaps in place over pump suction
- Prevents pea gravel from entering pump

xylem
Let's Solve Water

Xylem Inc.
2881 East Bayard Street Ext., Suite A
Seneca Falls, NY 13148
Phone: (866) 325-4210
Fax: (888) 322-5877
www.xylem.com/bellgossett

Bell & Gossett is a trademark of Xylem Inc. or one of its subsidiaries.
© 2020 Xylem Inc. BSC R6 March 2020