

**FEATURES**

Impeller: Cast iron, ASTM A48, Class 30, two vane semi-open, non-clog design with pump out vanes for mechanical seal protection. Computer balanced for smooth operation. Silicon bronze impeller is an option.

Casing: Heavy duty gray cast iron, ASTM A48, Class 30. Volute type casing with 4", 125#, flanged, horizontal discharge conforming to ANSI standards. Compatible with A10-40, A10-60 cast iron or A10-40B, A10-60B cast iron and brass (non-sparking) slide rail assembly.

Seals: Tandem mechanical seal system in an oil filled seal chamber. Each seal operates independently to ensure fail safe performance. Standard seals are carbon rotary and ceramic stationary. Outer seals are designed for easy replacement. Optional seals are available.

Seal Sensor Probes: Pump has a standard dual probe moisture detection system located in an oil filled seal chamber. The sensor leads must be connected to a "seal fail circuit" in the control panel.

4XWS

EXPLOSION PROOF SUBMERSIBLE SEWAGE PUMP

CLASS 1, DIVISION 1, GROUPS C AND D HAZARDOUS LOCATIONS



Bell & Gossett

a xylem brand

APPLICATIONS

Designed for a variety of hazardous commercial and industrial applications such as:

- Sewage systems
- Flood and pollution control
- Dewatering and effluent
- Hospitals
- Trailer courts
- Hotels and motels

SPECIFICATIONS

Pump:

- Maximum solid size: 3.0"
- Discharge size: 4" ANSI 125# Flange
- Maximum capacity: 650 GPM
- Maximum total head: 52'

MOTOR SPECIFICATIONS

- Maximum ambient temperature: 40° C (104° F)
- Rated for continuous duty with motor fully submerged
- Service Factor: 1.15
- HP range:
Three phase: 2 to 7.5 HP
- 60 Hz Voltages available:
Three phase: 200, 230, 460 and 575
- Insulation: Class F
- Single row ball bearings

MOTOR FEATURES

- **Explosion Proof Motor:** For use in hazardous locations. Rated Class 1, Groups C & D.
- **Standards:** All motors conform to the latest requirements of NEMA, IEEE, ANSI and NEC standards.
- **Air filled motor**
- **Class F insulation**
- **Thermal Protection System:** The motor is equipped with two automatic reset on-winding thermostats to protect it from high temperatures.
- **Operating Design:** Motors are designed for continuous submerged operation. The maximum allowable run time in air is 15 minutes.
- **Bearings:** Single row greased for life sealed bearings. Rated for minimum L10 life of 17,500 hours. The bearings are designed to carry the radial and thrust loads.
- **Cable Entry:** Power and control cables are epoxy encapsulated to prevent wicking even if the cable jacket is punctured. Buna-N grommets provide an additional cable seal.
- **Shaft:** The shaft is 416 stainless steel.
- **Power and Control Cables:** Standard length is 25', optional 50' is available. The power leads are sized from 14/4 to 10/4 depending on HP and voltage, rated as SOW and SOOW. The control cable is 18/5 SOW cable.

AGENCY LISTINGS



Tested to UL 778 and CSA 22.2 108 Standards
By Canadian Standards Association
File #218526

CONTROL PANEL REQUIREMENTS

To maintain warranty coverage and agency listings, Control Panels must have:

- Moisture Detection System - to warn of a seal failure.
- Thermal Protection System - winding thermostats open the pilot circuit of the magnetic motor controller before dangerous temperatures are reached.
- Overload (Over Current) Protection - Class 10, quick-trip type overload protection must be provided in

both three phase and single phase controls.

- Intrinsically Safe Relays - use "intrinsically safe relays" in a Class 1, Division 1, environment to power the float switches. They eliminate the danger of a spark if a switch cord becomes damaged. Intrinsically Safe Relays are available as an option from most panel suppliers. Other level control systems are available and may be applicable for this service, consult with your control manufacturer.

Typical Control Option:

- Guaranteed Pump Submergence Float - Many engineers specify a redundant OFF float or a Guaranteed Pump Submergence Circuit. This provides a second OFF float as protection from "OFF" float failure or hang up which protects the pump(s) from running dry.

*See CentriPro™ single phase control panel bulletin (BCP1PC1P-R-) or for three phase (BCPCF-R-).

PUMP ORDER NUMBERS AND GENERAL INFORMATION

Pump Order No.	HP	Imp. Dia.	Phase	Volts	RPM	1.15 SF Amps	Impeller Code	Full Load Amps	Locked Rotor Amps	Power Cord	Power Cable Diameter (in.)	18/5 Control Cable Dia. (in.)	Wt. (lbs.)
4XWS4G2A2K1C	2	5.69"	3	200	1750	7.6	K	6.8	50.6	14/4	0.58	0.495	270
4XWS4G3A2K1C				230		6.6		5.9	44.0				
4XWS4G4A2K1C				460		3.3		2.9	22.0				
4XWS4G5A2K1C				575		2.6		2.8	17.6				
4XWS4H2A2J1C	3	6.31"	3	200		11.3	J	10.1	71.5	14/4	0.58		
4XWS4H3A2J1C				230		9.8		8.8	62.1				
4XWS4H4A2J1C				460		4.9		4.4	31.1				
4XWS4H5A2J1C				575		3.9		3.5	24.9				
4XWS4J2A2H1C	5	7.12"	3	200		18.3	H	17.0	92.1	12/4	0.66		
4XWS4J3A2H1C				230		15.9		13.9	80.1				
4XWS4J4A2H1C				460		8.0		7.0	40.0				
4XWS4J5A2H1C				575		6.4		5.6	32.0	14/4	0.58		
4XWS4K2A2G1C	7½	7.69"	3	200		26.7	G	23.3	144.0	10/4	0.73		
4XWS4K3A2G1C				230		23.1		20.2	125.0				
4XWS4K4A2G1C				460		11.6		10.1	62.5				
4XWS4K5A2G1C				575		9.2		8.1	50.0	14/4	0.58		

NOMENCLATURE DESCRIPTION

1st - 4th Characters

4 = 4" 125# ANSI Flanged Discharge
 X = Explosion Proof, Dual Seal with Seal Fail (moisture) Sensors
 W = Wastewater (Sewage)
 S = Semi-open Impeller

5th Character - Phase

3 = Three Phase
 4 = Three Phase with Pilot Duty Thermal Sensors

6th Character - Horsepower

G = 2 J = 5
 H = 3 K = 7.5

7th Character - Voltage

2 = 200 4 = 460 8 = 380
 3 = 230 5 = 575

8th Character - Discharge Style

A = ANSI Vertical Flange for Horizontal Discharge

9th Character - Motor RPM / Hertz

1 = 3500/60 5 = 2900/50
 2 = 1750/60 6 = 1450/50
 3 = 1150/60 7 = 950/50

10th Character - Impeller Code

G = 7.69" 7.5 HP @ 1.15 Service Factor
 H = 7.12" 5 HP @ 1.15 Service Factor
 J = 6.31" 3 HP @ 1.15 Service Factor
 K = 5.69" 2 HP @ 1.15 Service Factor
 T = SPECIAL TRIM

11th Character - Lower (outer) Mechanical Seal

1 = Standard Lower Seal - Carbon rotary and ceramic/ stationary with BUNA elastomers and 304 SS metal parts.
 2 = Optional Lower Seal - Silicon carbide/rotary and silicon carbide stationary with Viton elastomers and 304 SS metal parts.
 3 = Optional Lower Seal - Silicon carbide/rotary and tungsten carbide stationary with Viton elastomers and 304 SS metal parts.

12th Cord Length

C = 25' (standard)
 F = 50'

13th Options

1 = Silicon bronze impeller
 2 = Epoxy coating
 3 = Both 1 & 2

APPLICATION DATA

Maximum Solid Size	3"
Minimum Casing Thickness	5/16"
Casing Corrosion Allowance	1/8"
Maximum Working Pressure	100 PSI
Maximum Submergence	200 feet depth
Maximum Environmental Temperature	40°C (104°F) ambient conditions
Maximum Starts Per Hour	10 evenly distributed starts/stops per hour

CONSTRUCTION DETAILS

Power Cable - Type	10/4, 12/4, 14/4 SOW, SOOW
Control / Sensor Cable / Type	18/5 SOW
Cable Cap Assembly	Leads have a Buna grommet and are encapsulated in epoxy for a positive seal
Power and Control Cable Lengths	25' standard, 50' optional
Motor Enclosure	Cast Iron, ASTM A-48, Class 30 (minimum)
Motor Shaft	416 Stainless Steel
Motor Design	NEMA Design B - Air-filled
Motor Insulation	Class "F", 155° C (310° F) insulation
Motor Thermal Protection	Two (2) normally closed on-winding thermostats open at 153° C (307° F), automatic reset closes at 140° C (284° F)
Motor Overload Protection	Three phase units require Class 10, quick-trip, ambient compensated overloads in the control panel
Motor Moisture Protection	Dual moisture sensing probes in an oil-filled seal chamber between inner and outer seals - Connect to a relay in control panel
Casing	Cast Iron, ASTM A-48, Class 30
Impeller	Cast Iron, ASTM A-48, Class 30 or Optional Cast Bronze ASTM B584 C87600
Impeller Type	Semi-open, non-clog with pump out vanes on back shroud, computer dynamically balanced

STANDARD PARTS

Ball Bearings	Greased for life, single row, upper and lower ball bearings, L10 rating life of 17,500 hours	
Mechanical Seals - Standard	Upper	Carbon - rotary / ceramic - stationary / Buna elastomers / 304SS metal parts
	Lower	
Mechanical Seals - Optional	Lower	Silicon carbide - rotary / silicon carbide - stationary / Viton / 304SS
	Lower	Silicon carbide - rotary / tungsten carbide - stationary / Viton / 304SS
Standard O-Rings	BUNA-N (nitrile)	
External Hardware	Stainless steel	

xylem
Let's Solve Water

Xylem Inc.
2881 East Bayard Street Ext., Suite A
Seneca Falls, NY 13148
Phone: (866) 325-4210
Fax: (888) 322-5877
www.bellgossett.com

Bell & Gossett is a trademark of Xylem Inc. or one of its subsidiaries.
© 2015 Xylem Inc. B4XWS R4 November 2015

DIMENSIONS

(All dimensions are in inches. Do not use for construction purposes.)

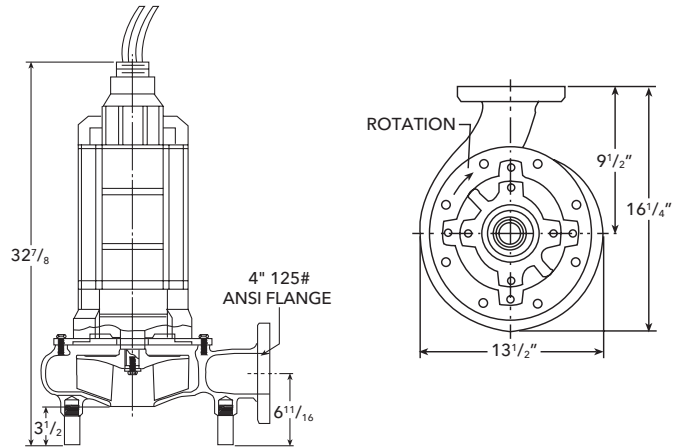

MATERIALS OF CONSTRUCTION

Item No.	Part Name	Material				
		Standard	Optional			
1	Impeller, non-clog	1003	1179			
2	Casing	1003				
3	Shaft-keyed	416 Series SS				
4	Fasteners	300 Series SS				
5	Impeller Bolt	Steel				
6	Motor Enclosure	Cast Iron				
7	Power and Control Cables	25', SOW/SOOW	50'			
8	Outer Mech. Seal	Service	Rotary	Stationary	Elastomers	Metal Parts
	OPT	Heavy duty	Silicon Carbide	Sil. Carb. Tung. Carb.	Viton	304 Series SS
	STD	Mild abrasives	Carbon	Ceramic	BUNA-N	304 Series SS
Material Code		Engineering Standard				
1003		Cast iron – ASTM A48 Class 30				
1179		Silicon bronze – ASTM B584 C87600				

