

<b>JOB:</b>   <b>UNIT TAG:</b> <b>ENGINEER:</b> <b>CONTRACTOR:</b>	<b>REPRESENTATIVE:</b>   <b>ORDER NO.</b> <b>SUBMITTED BY:</b> <b>APPROVED BY:</b>	<b>DATE:</b> <b>DATE:</b> <b>DATE:</b>
---	---	--

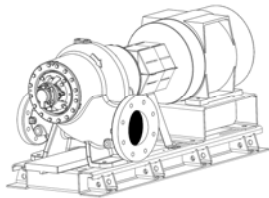

## Model VSH

### 8x10x10<sup>1</sup>/<sub>2</sub>A

#### Double Suction Split Case Pump



**SPECIFICATIONS**

FLOW \_\_\_\_\_ HEAD \_\_\_\_\_  
 HP \_\_\_\_\_ RPM \_\_\_\_\_  
 VOLTS \_\_\_\_\_  
 CYCLE \_\_\_\_\_ PHASE \_\_\_\_\_  
 ENCLOSURE \_\_\_\_\_  
 APPROX. WEIGHT \_\_\_\_\_  
 SPECIALS \_\_\_\_\_

**STANDARD MATERIALS OF CONSTRUCTION**

- Cast Iron Bronze Fitted
- Heavy Duty Maintenance Free Bearings
- Alignment Friendly Coupling
- Heavy Duty Groutless Baseplate
- ANSI/OSHA Coupling Guard
- ISO 1940-1:2003 Impeller Balance

**OPTIONAL MATERIALS OF CONSTRUCTION**

- Galvanized Drip Pan
- Spacer Coupling

**TYPE OF SEAL AND WORKING PRESSURE**

- Standard:** 175 PSIG (12 BAR) max. working pressure, flat face flanges, 125# ANSI flange drilling, Unitized mechanical seal, EPR/Carbon/Silicon Carbide, 175 PSIG (12 BAR) max. suction pressure, 0 to 300°F (-18 to 149°C)
- Optional:** 300 PSIG (20 BAR) max. working pressure, flat face flanges, 250# ANSI flange drilling, Unitized mechanical seal, EPR/Carbon/Silicon Carbide, 200 PSIG (13.7 BAR) max. suction pressure, 0 to 300°F (-18 to 149°C)
- Optional:** 300 PSIG (20 BAR) max. working pressure, flat face flanges, 250# ANSI flange drilling, balanced mechanical seal, EPR/Graphite loaded Silicon Carbide on Graphite loaded Silicon Carbide, 300 PSIG (20 BAR) max. suction pressure, 0 to 300°F (-18 to 149°C)

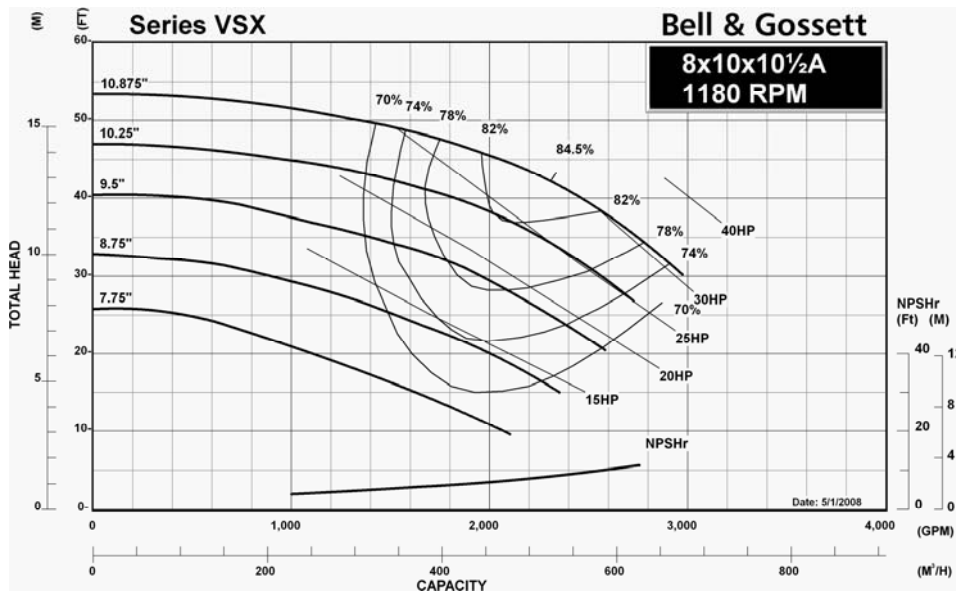

<b>JOB:</b>	<b>REPRESENTATIVE:</b>	
<b>UNIT TAG:</b>	<b>ORDER NO.:</b>	<b>DATE:</b>
<b>ENGINEER:</b>	<b>SUBMITTED BY:</b>	<b>DATE:</b>
<b>CONTRACTOR:</b>	<b>APPROVED BY:</b>	<b>DATE:</b>

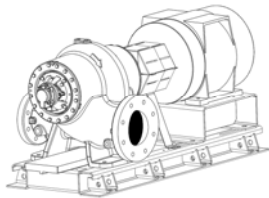

## Model VSH

### 8x10x10<sup>1</sup>/<sub>2</sub>A

#### Double Suction Split Case Pump



**SPECIFICATIONS**

FLOW \_\_\_\_\_ HEAD \_\_\_\_\_  
 HP \_\_\_\_\_ RPM \_\_\_\_\_  
 VOLTS \_\_\_\_\_  
 CYCLE \_\_\_\_\_ PHASE \_\_\_\_\_  
 ENCLOSURE \_\_\_\_\_  
 APPROX. WEIGHT \_\_\_\_\_  
 SPECIALS \_\_\_\_\_

**STANDARD MATERIALS OF CONSTRUCTION**

- Cast Iron Bronze Fitted
- Heavy Duty Maintenance Free Bearings
- Alignment Friendly Coupling
- Heavy Duty Groutless Baseplate
- ANSI/OSHA Coupling Guard
- ISO 1940-1:2003 Impeller Balance

**OPTIONAL MATERIALS OF CONSTRUCTION**

- Galvanized Drip Pan
- Spacer Coupling

**TYPE OF SEAL AND WORKING PRESSURE**

- Standard:** 175 PSIG (12 BAR) max. working pressure, flat face flanges, 125# ANSI flange drilling, Unitized mechanical seal, EPR/Carbon/Silicon Carbide, 175 PSIG (12 BAR) max. suction pressure, 0 to 300°F (-18 to 149°C)
- Optional:** 300 PSIG (20 BAR) max. working pressure, flat face flanges, 250# ANSI flange drilling, Unitized mechanical seal, EPR/Carbon/Silicon Carbide, 200 PSIG (13.7 BAR) max. suction pressure, 0 to 300°F (-18 to 149°C)
- Optional:** 300 PSIG (20 BAR) max. working pressure, flat face flanges, 250# ANSI flange drilling, balanced mechanical seal, EPR/Graphite loaded Silicon Carbide on Graphite loaded Silicon Carbide, 300 PSIG (20 BAR) max. suction pressure, 0 to 300°F (-18 to 149°C)

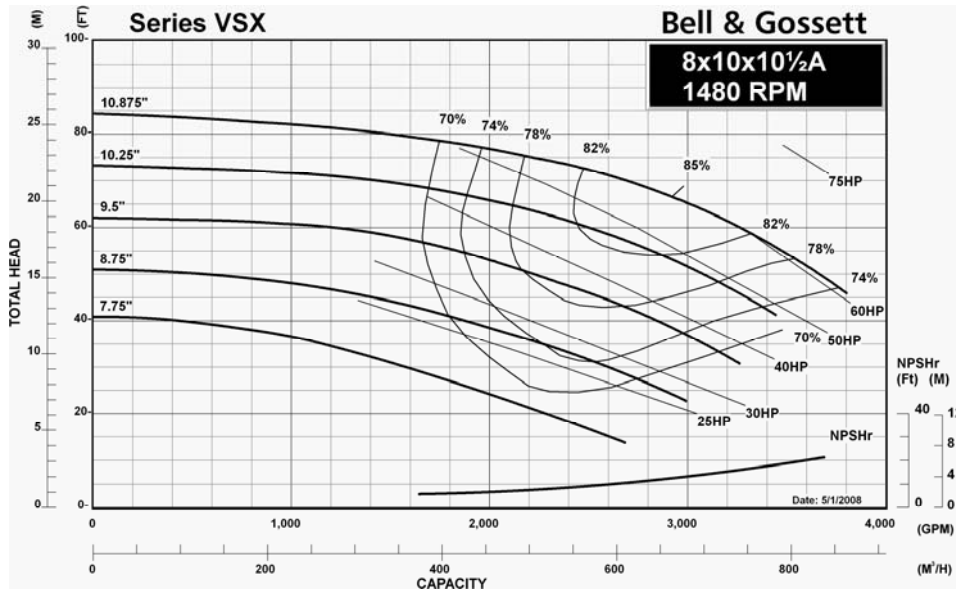

<b>JOB:</b>	<b>REPRESENTATIVE:</b>
<b>UNIT TAG:</b>	<b>ORDER NO.:</b>
<b>ENGINEER:</b>	<b>SUBMITTED BY:</b>
<b>CONTRACTOR:</b>	<b>APPROVED BY:</b>
	<b>DATE:</b>
	<b>DATE:</b>
	<b>DATE:</b>

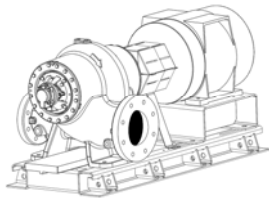

## Model VSH 8x10x10<sup>1</sup>/<sub>2</sub>A Double Suction Split Case Pump



**SPECIFICATIONS**

FLOW \_\_\_\_\_ HEAD \_\_\_\_\_  
 HP \_\_\_\_\_ RPM \_\_\_\_\_  
 VOLTS \_\_\_\_\_  
 CYCLE \_\_\_\_\_ PHASE \_\_\_\_\_  
 ENCLOSURE \_\_\_\_\_  
 APPROX. WEIGHT \_\_\_\_\_  
 SPECIALS \_\_\_\_\_

**STANDARD MATERIALS OF CONSTRUCTION**

- Cast Iron Bronze Fitted
- Heavy Duty Maintenance Free Bearings
- Alignment Friendly Coupling
- Heavy Duty Groutless Baseplate
- ANSI/OSHA Coupling Guard
- ISO 1940-1:2003 Impeller Balance

**OPTIONAL MATERIALS OF CONSTRUCTION**

- Galvanized Drip Pan
- Spacer Coupling

**TYPE OF SEAL AND WORKING PRESSURE**

- Standard:** 175 PSIG (12 BAR) max. working pressure, flat face flanges, 125# ANSI flange drilling, Unitized mechanical seal, EPR/Carbon/Silicon Carbide, 175 PSIG (12 BAR) max. suction pressure, 0 to 300°F (-18 to 149°C)
- Optional:** 300 PSIG (20 BAR) max. working pressure, flat face flanges, 250# ANSI flange drilling, Unitized mechanical seal, EPR/Carbon/Silicon Carbide, 200 PSIG (13.7 BAR) max. suction pressure, 0 to 300°F (-18 to 149°C)
- Optional:** 300 PSIG (20 BAR) max. working pressure, flat face flanges, 250# ANSI flange drilling, balanced mechanical seal, EPR/Graphite loaded Silicon Carbide on Graphite loaded Silicon Carbide, 300 PSIG (20 BAR) max. suction pressure, 0 to 300°F (-18 to 149°C)

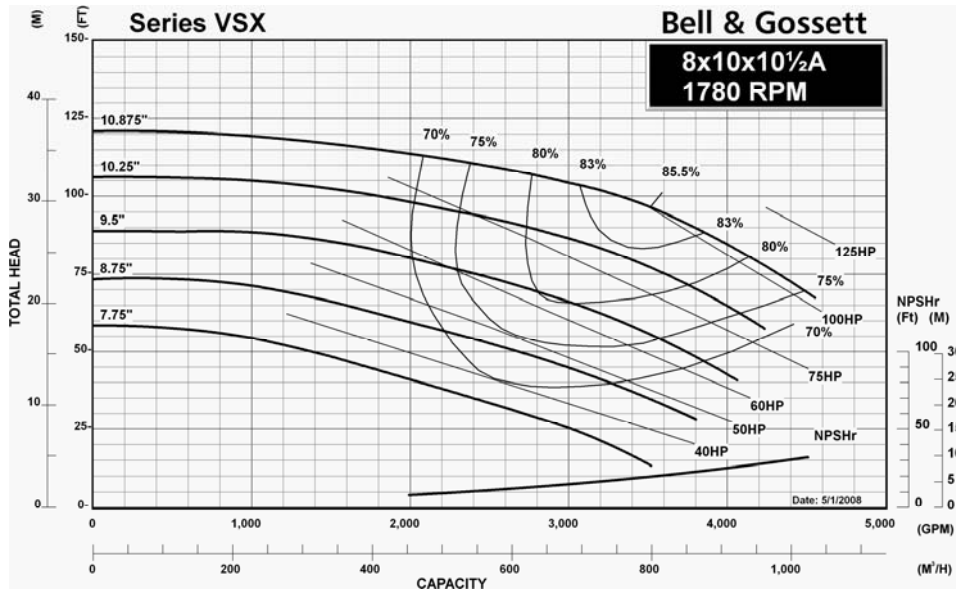

# Model VSH 8x10x10½A Centrifugal Pump Submittal

B-870.3

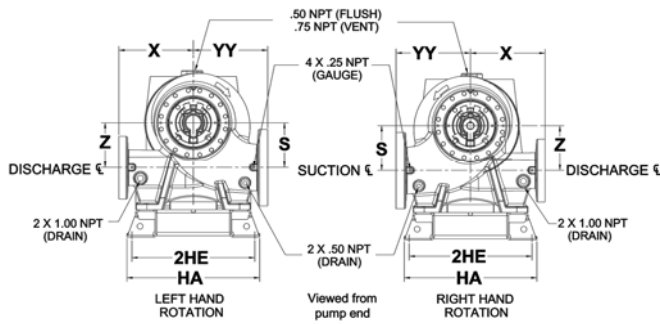

FLANGE DIMENSIONS IN INCHES (MM)			
	SIZE	THICKNESS	O.D.
Discharge	8"	1.88 (48)	14.75 (375)
Suction	10"	2.13 (54)	17.00 (432)

FLANGES ARE 125# ANSI - STANDARD  
250# ANSI - AVAILABLE

DIMENSIONS IN INCHES (MM)				
S	VH	X	YY	Z
8.97 (228)	10.625 (270)	15.5 (394)	15.5 (394)	8.97 (228)

Removal clearance from end  
of bracket: 24 Inches (610 mm)

## STANDARD COUPLER

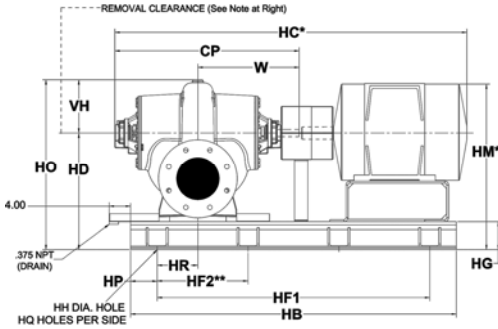

\* Motor dimensions are approximate and vary by manufacturer and motor type.  
\*\* Dimensions vary due to coupler gap based on horse power.  
\*\*\* Distance to the next available hole.

MOTOR FRAME	DIMENSIONS - INCHES (mm) FOR STANDARD COUPLER															
	CP	HA	HB	HC*	HD	2HE	HF <sub>1</sub>	HF <sub>2</sub> ***	HG	HH	HM*	HO	HP	HQ	HR	W
254T	34.48 (876)	23.9 (607)	61 (1549)	58.495 (1486)	23.25 (591)	19.9 (505)	51 (1295)	25.5 (648)	5.25 (133)	1.125 (29)	31.07 (789)	33.875 (860)	5 (127)	3	7.625 (194)	18.93 (481)
256T	34.48 (876)	23.9 (607)	61 (1549)	60.245 (1530)	23.25 (591)	19.9 (505)	51 (1295)	25.5 (648)	5.25 (133)	1.125 (29)	31.07 (789)	33.875 (860)	5 (127)	3	7.625 (194)	18.93 (481)
284T/TS	34.48 (876)	23.9 (607)	61 (1549)	61.408 (1560)	23.25 (591)	19.9 (505)	51 (1295)	25.5 (648)	5.25 (133)	1.125 (29)	31.07 (789)	33.875 (860)	5 (127)	3	7.625 (194)	18.93 (481)
286T/TS	34.48 (876)	23.9 (607)	61 (1549)	62.904 (1598)	23.25 (591)	19.9 (505)	51 (1295)	25.5 (648)	5.25 (133)	1.125 (29)	31.07 (789)	33.875 (860)	5 (127)	3	7.625 (194)	18.93 (481)
324T/TS	34.48 (876)	23.9 (607)	61 (1549)	65.725 (1669)	23.25 (591)	19.9 (505)	51 (1295)	25.5 (648)	5.25 (133)	1.125 (29)	31.82 (789)	33.875 (860)	5 (127)	3	7.625 (194)	18.93 (481)
326T/TS	34.48 (876)	23.9 (607)	61 (1549)	66.845 (1698)	23.25 (591)	19.9 (505)	51 (1295)	25.5 (648)	5.25 (133)	1.125 (29)	32.35 (822)	33.875 (860)	5 (127)	3	7.625 (194)	18.93 (481)
364T/TS	34.48 (876)	23.9 (607)	61 (1549)	68.684 (1745)	23.25 (591)	19.9 (505)	51 (1295)	25.5 (648)	5.25 (133)	1.125 (29)	33.2 (843)	33.875 (860)	5 (127)	3	7.625 (194)	18.93 (481)
365T/TS	34.48 (876)	23.9 (607)	61 (1549)	68.684 (1745)	23.25 (591)	19.9 (505)	51 (1295)	25.5 (648)	5.25 (133)	1.125 (29)	33.2 (843)	33.875 (860)	5 (127)	3	7.625 (194)	18.93 (481)
404T/TS	34.48 (876)	23.9 (607)	70 (1778)	71.785** (1745)	23.25 (591)	19.9 (505)	60 (1524)	20 (508)	5.25 (133)	1.125 (29)	33.72 (856)	33.875 (860)	5 (127)	4	7.625 (194)	18.93 (481)
405T/TS	34.48 (876)	23.9 (607)	70 (1778)	73.785** (1861)	23.25 (591)	19.9 (505)	60 (1524)	20 (508)	5.25 (133)	1.125 (29)	33.72 (856)	33.875 (860)	5 (127)	4	7.625 (194)	18.93 (481)
444T/TS	34.48 (876)	23.9 (607)	70 (1778)	79.251 (2000)	23.25 (591)	19.9 (505)	60 (1524)	20 (508)	5.25 (133)	1.125 (29)	38.77 (985)	33.875 (860)	5 (127)	4	7.625 (194)	18.93 (481)
445T/TS	34.48 (876)	23.9 (607)	70 (1778)	80.855 (2054)	23.25 (591)	19.9 (505)	60 (1524)	20 (508)	5.25 (133)	1.125 (29)	38.77 (985)	33.875 (860)	5 (127)	4	7.625 (194)	18.93 (481)

Dimensions are subject to change. Not to be used for construction purposes unless certified.  
Units may be built where foot/feet overhang the motor mounting platform. If overhang is unacceptable, consult factory for a custom submittal, quotation and/or lead time. A certified motor drawing will be required.

Xylem Inc.  
8200 N. Austin Avenue  
Morton Grove, IL 60053  
Phone: (847)966-3700  
Fax: (847)965-8379  
www.xylem.com/brands/bellgossett



# Model VSH 8x10x10½A Centrifugal Pump Submittal

B-870.3

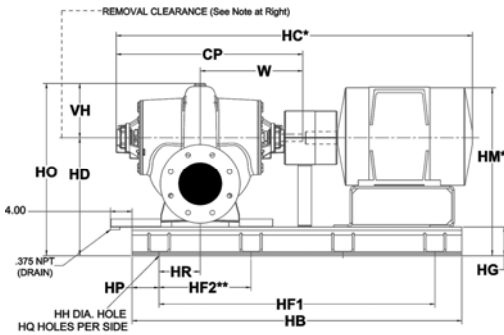
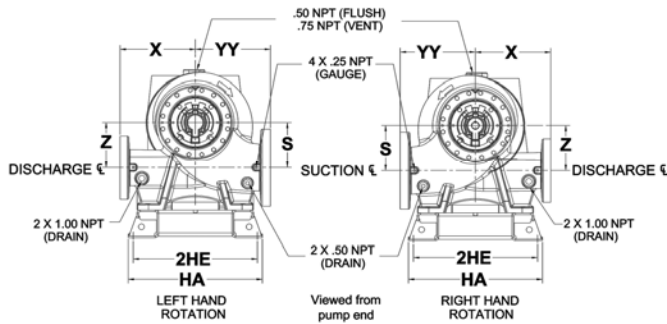

FLANGE DIMENSIONS IN INCHES (MM)			
	SIZE	THICKNESS	O.D.
Discharge	8"	1.88 (48)	14.75 (375)
Suction	10"	2.13 (54)	17.00 (432)

FLANGES ARE 125# ANSI - STANDARD  
250# ANSI - AVAILABLE

DIMENSIONS IN INCHES (MM)				
S	VH	X	YY	Z
8.97 (228)	10.625 (270)	15.5 (394)	15.5 (394)	8.97 (228)

Removal clearance from end  
of bracket: 24 Inches (610 mm)

## SPACER COUPLER

\*Motor dimensions are approximate and vary by manufacturer and motor type.

\*\*Dimensions vary due to coupler gap based on horse power.

\*\*\*Distance to the next available hole.

MOTOR FRAME	DIMENSIONS - INCHES (mm) FOR SPACER COUPLER****															
	CP	HA	HB	HC*	HD	2HE	HF <sub>1</sub>	HF <sub>2</sub> ***	HG	HH	HM*	HO	HP	HQ	HR	W
254T	34.48 (876)	23.9 (607)	70 (1778)	69.745 (1772)	23.25 (591)	19.9 (505)	60 (1524)	20 (508)	5.25 (133)	1.125 (29)	31.07 (789)	33.875 (860)	5 (127)	4	7.625 (194)	18.93 (481)
256T	34.48 (876)	23.9 (607)	70 (1778)	71.495 (1816)	23.25 (591)	19.9 (505)	60 (1524)	20 (508)	5.25 (133)	1.125 (29)	31.07 (789)	33.875 (860)	5 (127)	4	7.625 (194)	18.93 (481)
284T/TS	34.48 (876)	23.9 (607)	70 (1778)	72.658 (1846)	23.25 (591)	19.9 (505)	60 (1524)	20 (508)	5.25 (133)	1.125 (29)	31.07 (789)	33.875 (860)	5 (127)	4	7.625 (194)	18.93 (481)
286T/TS	34.48 (876)	23.9 (607)	70 (1778)	74.154 (1884)	23.25 (591)	19.9 (505)	60 (1524)	20 (508)	5.25 (133)	1.125 (29)	31.07 (789)	33.875 (860)	5 (127)	4	7.625 (194)	18.93 (481)
324T/TS	34.48 (876)	23.9 (607)	80 (2032)	76.975 (1955)	23.25 (591)	19.9 (505)	70 (1778)	23.33 (593)	5.25 (133)	1.125 (29)	31.82 (789)	33.875 (860)	5 (127)	4	7.625 (194)	18.93 (481)
326T/TS	34.48 (876)	23.9 (607)	80 (2032)	78.095 (1984)	23.25 (591)	19.9 (505)	70 (1778)	23.33 (593)	5.25 (133)	1.125 (29)	32.35 (822)	33.875 (860)	5 (127)	4	7.625 (194)	18.93 (481)
364T/TS	34.48 (876)	23.9 (607)	80 (2032)	79.934 (2030)	23.25 (591)	19.9 (505)	70 (1778)	23.33 (593)	5.25 (133)	1.125 (29)	33.2 (843)	33.875 (860)	5 (127)	4	7.625 (194)	18.93 (481)
365T/TS	34.48 (876)	23.9 (607)	80 (2032)	79.934 (2030)	23.25 (591)	19.9 (505)	70 (1778)	23.33 (593)	5.25 (133)	1.125 (29)	33.2 (843)	33.875 (860)	5 (127)	4	7.625 (194)	18.93 (481)
404T/TS	34.48 (876)	23.9 (607)	80 (2032)	82.535 (2096)	23.25 (591)	19.9 (505)	70 (1778)	23.33 (593)	5.25 (133)	1.125 (29)	33.72 (856)	33.875 (860)	5 (127)	4	7.625 (194)	18.93 (481)
405T/TS	34.48 (876)	23.9 (607)	80 (2032)	84.535 (2147)	23.25 (591)	19.9 (505)	70 (1778)	23.33 (593)	5.25 (133)	1.125 (29)	33.72 (856)	33.875 (860)	5 (127)	4	7.625 (194)	18.93 (481)
444T/TS	34.48 (876)	23.9 (607)	80 (2032)	90.001 (2286)	23.25 (591)	19.9 (505)	70 (1778)	23.33 (593)	5.25 (133)	1.125 (29)	38.77 (985)	33.875 (860)	5 (127)	4	7.625 (194)	18.93 (481)
445T/TS	34.48 (876)	23.9 (607)	80 (2032)	91.605 (2327)	23.25 (591)	19.9 (505)	70 (1778)	23.33 (593)	5.25 (133)	1.125 (29)	38.77 (985)	33.875 (860)	5 (127)	4	7.625 (194)	18.93 (481)

Dimensions are subject to change. Not to be used for construction purposes unless certified.

Units may be built where foot/feet overhang the motor mounting platform. If overhang is unacceptable, consult factory for a custom submittal, quotation and/or lead time. A certified motor drawing will be required.

\*\*\*\*These dimensions are valid when using the Woods Duraflex or Dodge Paraflex spacer coupling option. For dimensions on Falk SteelFlex coupling options, consult factory for a special submittal drawing.

Xylem Inc.  
8200 N. Austin Avenue  
Morton Grove, IL 60053  
Phone: (847)966-3700  
Fax: (847)965-8379  
www.xylem.com/brands/bellgossett

