



INSTRUCTION MANUAL

ADAQCPC R1

AQUAVAR[®] CPC

Modbus[®] Communications (Software Version 204 and later)*

ADDENDUM TO THE INSTALLATION AND OPERATION MANUAL (IM167)

* Aquavar CPC units with software 204 and later will work with MODBUS. Previous versions will not. Go to GROUP 99 in the programming and verify firmware (FW) version.

TABLE OF CONTENTS

Overview.....	3
Setting Up Modbus Communications.....	3
Wiring.....	4
Setting Drive Parameters	6
Start / Stop Control.....	6
Remote Setting of Set Point 1	7
0xxxx Mapping Modbus Coils / Aquavar Control Word.....	8
1xxxx Mapping - Modbus Discrete Inputs / Aquavar Status Word.....	9
3xxxx Mapping - Modbus Inputs	10
4xxxx Register Mapping	11
Warranty.....	20

OVERVIEW

The Modbus® protocol was introduced by Modicon, Inc. for use in control environments featuring Modicon programmable controllers. Due to its ease of use and implementation, this common PLC language was quickly adopted as a de-facto standard for integration of a wide variety of master controllers and slave devices. Modbus is a serial, asynchronous protocol. Transactions are half-duplex, featuring a single Master controlling one or more Slaves. While RS232 can be used for point-to-point communication between a single Master and a single Slave, a more common implementation features a multi-drop RS485 network with a single Master controlling multiple Slaves. The AQUAVAR CPC features RS485 for its Modbus physical interface. In all cases, the AQUAVAR CPC will act as a slave in the network.

RTU

The Modbus specification defines two distinct transmission modes: ASCII and RTU. The AQUAVAR CPC supports RTU only.

SETTING UP MODBUS COMMUNICATIONS

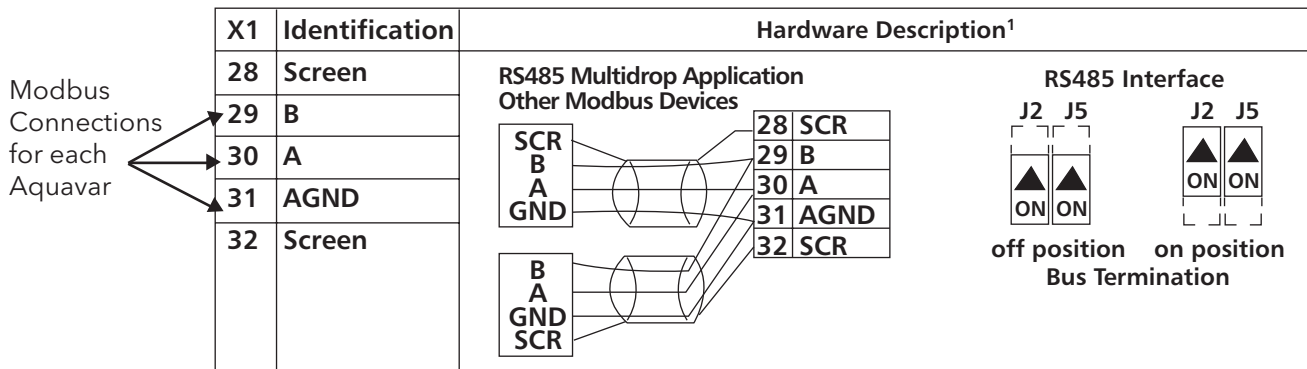
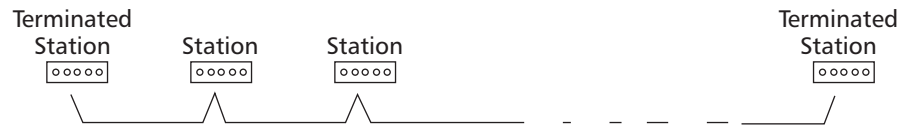

¹ For functional descriptions, see "Standard Serial Communication" addendum.

WIRING

Physical wiring of the MODBUS communication cable is to the RS485 terminal block, 28, 29 and 30. Use the screen connections if the cable has one.

NOTE: The only application macros that will work with Modbus communications enabled are: [1] Single Pump, [4] Constant Slv and [5] Speed Cntrl. See parameter 1102 *Applic Macro. Multicontrol or Synchronous will not work with MODBUS. Set macro to SINGLE PUMP, Constant Slv or Speed Cntrl.*

Configure Modbus Serial Communications

- 1. Set EFB Station ID** - This is the address of each Aquavar on the network. Each drive must have a unique station ID on the network.
 - a. Go to Group 32 - EFB PROTOCOL, press SEL.
 - b. Go to parameter 3202 - EFB STATION ID, press EDIT.
 - c. Set desired station ID using the UP or DOWN arrows, press SAVE.

Valid addresses are 1 - 247.

NOTE: Address 0 is used to broadcast messages to all slaves on the network.

NOTE: It is the user's responsibility to ensure that reading and writing is done to the correct address (Aquavar or node) in the network. Reading or writing to the wrong node can cause unexpected results.

- 2. Set EFB Baud Rate** - The settings used must be the same on the Modbus Master and the slaves (Aquavar CPC). Default rate is 9.6 kb/s.
 - a. Go to Group 32 - EFB PROTOCOL, press SEL.
 - b. Go to parameter 3203 - EFB BAUD RATE, press EDIT.
 - c. Set the desired Baud Rate using the UP or DOWN arrows, press SAVE.

Valid baud rates are:	
1.2 kb/s	19.2 kb/s
2.4 kb/s	38.4 kb/s
4.8 kb/s	57.6 kb/s
9.6 kb/s	76.8 kb/s

WIRING

3. Set EFB Parity - The settings used must be the same on the Modbus Master and the slaves (Aquavar CPC). Default parity is 8N2 (8 data bits, no parity, two stop bits).

- a. Go to Group 32 - EFB PROTOCOL, press SEL.
- b. Go to parameter 3204 - EFB PARITY, press EDIT.
- c. Set the desired Parity using the UP or DOWN arrows, press SAVE.

Valid Parity settings are:
0 = 8N1 - 8 data bits, No parity, one stop bit.
1 = 8N2 - 8 data bits, No parity, two stop bits.
2 = 8E1 - 8 data bits, Even parity, one stop bit.
3 = 8O1 - 8 data bits, Odd parity, one stop bit.

4. Set EFB Ctrl Profile - The Aquavar Profile may be the only the only profile that can be selected.

- a. Go to Group 32 - EFB PROTOCOL, press SEL.
- b. Go to parameter 3205 - EFB CTRL PROFILE, press EDIT.
- c. Set the desired profile using the UP or DOWN arrows, press SAVE.

Valid Profile settings are:
1 = AQUAVAR

Activate Modbus Communications on the Aquavar

1. Go to Group 30 - Options, press SEL.
2. Press Edit.
3. Using the UP or DOWN keys, select [1] STD MODBUS.
4. Press SAVE. Modbus Communications are now active.

SETTING DRIVE PARAMETERS

Note: With Modbus, any parameter can be accessed using the format: "4" followed by the parameter number. See the following example:

Changing Ramps 1 and 2 via Modbus from 5 to 10 seconds on a drive over 15 HP.

1. Set parameter 1102 (Applic Macro) to: [1] Single Pump, [4] Constant Slv, or [5] Speed Cntrl.
2. Configure and Setup Modbus Serial Communications
3. Ramp 1 is parameter 1301 and Ramp 2 is parameter 1302.
4. Write '100' to Holding Register 41301. Assuming no errors occur during this transaction, 1301 (Ramp 1) should now be set to 10.0 seconds.

Note: There is an implied decimal point that is not written between the first (from the right) and second digit. Thus 100 = 10.0

5. Write '100' to Holding Register 41302. 1302 (Ramp 2) should now be set to 10.0 seconds.

START / STOP CONTROL

Start

1. Set parameter 1102 (Applic Macro) to: [1] Single Pump, [4] Constant Slv, or [5] Speed Cntrl.
2. Configure and Setup Modbus Serial Communications
3. Set parameter 1201 to [1] Fieldbus
4. To Start, write '1' to Register 00002. Register 00001 (Stop) must be set '0'. The rotation arrow on the display should now be spinning and the drive will start if the actual pressure is below the setpoint.
5. Write '0' to Register 00002. The drive will continue to run as long as Register 00001 is '0'.

Stop

1. To Stop, write '1' to Register 00001. Register 00002, should be set to '0'. The rotation arrow on the display should stop rotating.

REMOTE SETTING OF SET POINT 1

1. Set parameter 1102 (Applic Macro) to: [1] Single Pump, [4] Constant Slv, or [5] Speed Cntrl.
2. Configure and Setup Modbus Serial Communications.
3. Set parameter 1601 to [0] Setp1.
4. Set parameter 1602 to [2] Fieldbus.
5. Write a value between '10000' and '0' (100.00% to 0% of Transducer Max) to Holding Register 40003.

Note: There is an implied decimal point that is not written between the second (from the right) and third digit. Thus, 10000 = 100.00%.

REMOTE SETTING OF SET POINT 1

For example, using the standard 300 PSI transducer supplied with the Aquavar CPC:

1. Parameter 1502 (Transducer Max) should be set to 300 PSI.
2. Parameter 1503 (Transducer Min) should be set to 0 PSI.
3. Setting to 60 PSI...
 - a. $60 \text{ PSI} / 300 \text{ PSI} = .2$ or 20%
 - b. Write '2000' to Holding Register 40003
4. Setting to 80 PSI...
 - a. $80 \text{ PSI} / 300 \text{ PSI} = \sim .2667$ or 26.67%
 - b. Write '2667' to Holding Register 40003

Speed Control through Modbus Interface

1. Set parameter 1102 (Applic Macro) to: [5] Speed Cntrl
2. Configure and Setup Modbus Serial Communications
3. Set parameter 1601 to [0] Setp1
4. Set parameter 1602 to [2] Fieldbus
5. Write a value between '10000' and '0' [100.00% to 0% of Maximum Freq (1401)] to Holding Register 40002.

Note: There is an implied decimal point that is not written between the second (from the right) and third digit. Thus, 10000 = 100.00%.

For example, using a Maximum Freq of 60 Hz:

1. Parameter 1401 (Maximum Freq) should be set to 60Hz.
2. Parameter 1601 (SP1 / SP2 Select) should be set to 0psi.
3. Parameter 1602 (Set Point 1 Select) should be set to [2] Fieldbus
4. Setting to 60 Hz (Full Speed)...
 - a. $60 \text{ Hz} / 60 \text{ Hz} = 1$ or 100%
 - b. Write '10000' to Holding Register 40002.

Note: Writing to parameter 1403 will have no effect.

5. Setting to 30 Hz (Half Speed)...
 - a. $30 \text{ Hz} / 60 \text{ Hz} = .5$ or 50%
 - b. Write '5000' to Holding Register 40002.

Note: Writing to parameter 1403 will have no effect.

OXXXX MAPPING MODBUS COILS / AQUAVAR CONTROL WORD

Modbus Ref.	Internal Location	R/W	Command	Value	Notes:
00001	Control Word - Bit 0	R/W	STOP	1 = STOP, 0 = (no op)	STOP Bit Must be set to 0 to start drive via Modbus. If both STOP and START are set to 1, drive will stop or remain stopped.
00002	Control Word - Bit 1	R/W	START	1 = START, 0 = (no op)	
00003	Control Word - Bit 2	n/a	Reserved (Not Used)		
00004	Control Word - Bit 3	n/a	Reserved (Not Used)		
00005	Control Word - Bit 4	R/W	RESET	1 = RESET, 0 = (no op)	
00006	Control Word - Bit 5	R/W	EXT2	1 = EXT2, 0 = EXT1	
00007	Control Word - Bit 6	n/a	Reserved (Not Used)		
00008	Control Word - Bit 7	n/a	Reserved (Not Used)		
00009	Control Word - Bit 8	n/a	Reserved (Not Used)		
00010	Control Word - Bit 9	n/a	Reserved (Not Used)		
00011	Control Word - Bit 10	n/a	Reserved (Not Used)		
00012	Control Word - Bit 11	n/a	Reserved (Not Used)		
00013	Control Word - Bit 12	n/a	Reserved (Not Used)		
00014	Control Word - Bit 13	n/a	Reserved (Not Used)		
00015	Control Word - Bit 14	n/a	Reserved (Not Used)		
00016	Control Word - Bit 15	n/a	Reserved (Not Used)		
00017	Control Word - Bit 16	n/a	Reserved (Not Used)		
00018	Control Word - Bit 17	n/a	Reserved (Not Used)		
00019	Control Word - Bit 18	n/a	Reserved (Not Used)		
00020	Control Word - Bit 19	n/a	Reserved (Not Used)		
00021	Control Word - Bit 20	n/a	Reserved (Not Used)		
00022	Control Word - Bit 21	n/a	Reserved (Not Used)		
00023	Control Word - Bit 22	n/a	Reserved (Not Used)		
00024	Control Word - Bit 23	n/a	Reserved (Not Used)		
00025	Control Word - Bit 24	n/a	Reserved (Not Used)		
00026	Control Word - Bit 25	n/a	Reserved (Not Used)		
00027	Control Word - Bit 26	n/a	Reserved (Not Used)		
00028	Control Word - Bit 27	n/a	Reserved (Not Used)		
00029	Control Word - Bit 28	n/a	Reserved (Not Used)		
00030	Control Word - Bit 29	n/a	Reserved (Not Used)		
00031	Control Word - Bit 30	n/a	Reserved (Not Used)		
00032	Control Word - Bit 31	n/a	Reserved (Not Used)		
00033	Not used in CW	R/W	RELAY OUTPUT 1	1 = Energize, 0 = Denergize	
00034	Not used in CW	R/W	RELAY OUTPUT 2	1 = Energize, 0 = Denergize	
00035	Not used in CW	R/W	RELAY OUTPUT 3	1 = Energize, 0 = Denergize	
00036	RESERVED	n/a	Reserved (Not Used)		
00037	RESERVED	n/a	Reserved (Not Used)		
00038	RESERVED	n/a	Reserved (Not Used)		

Supported Function Codes

01 - Read Coil Status

05 - Force Single Coil

15 - Force Multiple Coils (0x0F Hex)

1XXXX MAPPING - MODBUS DISCRETE INPUTS / AQUAVAR STATUS WORD

Modbus Ref.	Internal Location	R/W	Indication	Value
10001	Status Word - Bit 0	R	READY	1 = READY, 0 = NOT READY
10002	Status Word - Bit 1	R	ENABLED	1 = ENABLED, 0 = NOT ENABLED
10003	Status Word - Bit 2	R	STARTED	1 = STARTED, 0 = NOT STARTED
10004	Status Word - Bit 3	R	Reserved (Not Used)	
10005	Status Word - Bit 4	R	ZERO_SPEED	1 = 0 Hz, 0 = > 0 Hz
10006	Status Word - Bit 5	R	ACCELERATE	1 = ACCELERATING, 0 = NOT ACCELERATING
10007	Status Word - Bit 6	R	DECELERATE	1 = DECELERATING, 0 = NOT DECELERATING
10008	Status Word - Bit 7	R	AT_SPEED	1 = MAX FREQUENCY, 0 = NOT MAX FREQUENCY
10009	Status Word - Bit 8	R	Reserved (Not Used)	
10010	Status Word - Bit 9	R	Reserved (Not Used)	
10011	Status Word - Bit 10	R	Reserved (Not Used)	
10012	Status Word - Bit 11	R	Reserved (Not Used)	
10013	Status Word - Bit 12	R	PANEL_LOCAL	0 = NOT LOCAL 1 = LOCAL
10014	Status Word - Bit 13	R	Reserved (Not Used)	
10015	Status Word - Bit 14	R	EXT2_ACT	0 =Speed Control Mode 1 = All Other Macros
10016	Status Word - Bit 15	R	FAULT	0 = NO FAULT, 1 = FAULT
10017	Status Word - Bit 16	R	ALARM	0 = NO ALARM, 1 = ALARM
10018	Status Word - Bit 17	R	REQ_MAINT	
10019	Status Word - Bit 18	R	Reserved (Not Used)	
10020	Status Word - Bit 19	R	LOCAL LOCK	0 = LOCAL LOCK OFF, 1 = LOCAL LOCK ON
10021	Status Word - Bit 20	R	Reserved (Not Used)	
10022	Status Word - Bit 21	R	Reserved (Not Used)	
10023	Status Word - Bit 22	R	Reserved (Not Used)	
10024	Status Word - Bit 23	R	Reserved (Not Used)	
10025	Status Word - Bit 24	R	Reserved (Not Used)	
10026	Status Word - Bit 25	R	Reserved (Not Used)	
10027	Status Word - Bit 26	R	Reserved (Not Used)	
10028	Status Word - Bit 27	R	Reserved (Not Used)	
10029	Status Word - Bit 28	R	Reserved (Not Used)	
10030	Status Word - Bit 29	R	Reserved (Not Used)	
10031	Status Word - Bit 30	R	Reserved (Not Used)	
10032	Status Word - Bit 31	R	Reserved (Not Used)	
10033	DI1	R	DI1	0 = OFF, 1 = ON
10034	DI2	R	DI2	0 = OFF, 1 = ON
10035	DI3	R	DI3	0 = OFF, 1 = ON
10036	DI4	R	DI4	0 = OFF, 1 = ON
10037	DI5	R	DI5	0 = OFF, 1 = ON
10038	DI6	R	DI6	0 = OFF, 1 = ON

Supported Function Codes

02 - Read Input Status

3XXXX MAPPING - MODBUS INPUTS

Modbus Ref.	VFD Signal	R/W	Remarks
30001	AI1	R	This Register shall report the level of Analog Input 1 (0 ...100%)
30002	AI2 (Transducer)	R	This Register shall report the level of Analog Input 2 (0 ...100%)

Supported Function Codes

04 - Read Input Registers

4XXXX REGISTER MAPPING

Modbus Ref.	Contents	R/W	Remarks
40002	Reference 1	R/W	Use for Speed Control Macro Only Range = 0 ... 10000 (0 ... 100.00%)
40003	Reference 2 (Setpoint)	R/W	Remote Setpoint via Modbus Range = 0 ... 10000 (0 ... 100.00%) of Transducer range. e.g. 0 = 0 psi and 10000 = 300 PSI. NOTE: Group 16 Setpoint Select must be set to Fieldbus
40005	Actual 1 (Select using 3210)	R	By default, stores nothing. Use parameter 3210 to select an actual value for this register. e.g. 3210 = 0101, 40006 = Motor Freq.
40006	Actual 2 (Select using 3211)	R	By default, stores nothing. Use parameter 3211 to select an actual value for this register.
40007	Actual 3 (Select using 3213)	R	By default, stores nothing. Use parameter 3213 to select an actual value for this register.
40008	Actual 4 (Select using 3214)	R	By default, stores nothing. Use parameter 3214 to select an actual value for this register.
40009	Actual 5 (Select using 3214)	R	By default, stores nothing. Use parameter 3215 to select an actual value for this register.
40010	Actual 6 (Select using 3214)	R	By default, stores nothing. Use parameter 3216 to select an actual value for this register.
40011	Actual 7 (Select using 3214)	R	By default, stores nothing. Use parameter 3217 to select an actual value for this register.
40012	Actual 8 (Select using 3214)	R	By default, stores nothing. Use parameter 3218 to select an actual value for this register.
40031	Aquavar Control Word LSW	R/W	Maps directly to the Least Significant Word of the Aquavar profile's CONTROL WORD.
40032	Aquavar Control Word MSW	R	Maps directly to the Most Significant Word of the Aquavar profile's CONTROL WORD.
40033	Aquavar Status Word LSW	R	Maps directly to the Least Significant Word of the Aquavar profile's STATUS WORD.
40034	Aquavar Status Word MSW	R	Maps directly to the Most Significant Word of the Aquavar profile's STATUS WORD.

DRIVE PARAMETERS

Group 1	VFD Signal	R/W	Set Value (Dec)
40101	Motor Frequency	R	–
40102	Motor Current	R	–
40103	Motor Power	R	–
40104	DC Bus Voltage	R	–
40105	Motor Voltage	R	–
40106	Drive Temp	R	–
40107	VFD On Time	R	–
40108	Run Time	R	–
40109	KWh Counter	R	–
40110	DI6-1 Status	R	–
40111	AI1	R	–
40112	AI2 Trnsdcr Fdbk	R	–
40113	RO3-1 Status	R	–
40114	AO1 (mA)	R	–
40115	AO2 (mA)	R	–
40116	Last Fault	R	–
40117	Previous Fault 1	R	–
40118	Previous Fault 2	R	–

4XXXX REGISTER MAPPING

DRIVE PARAMETERS

Group 1	VFD Signal	R/W	Set Value (Dec)
40119	Fault Time 1	R	–
40120	Fault Time 2	R	–
40121	Speed at Flt	R	–
40122	Freq at Flt	R	–
40123	Voltage at Flt	R	–
40124	Current at Flt	R	–
40125	Status at Flt	R	–
40126	DI 6-1 At Fault	R	–
40127	Drive On Time Hi	R	–
40128	Drive On Time Lo	R	–

Group 2	VFD Signal	R/W	Set Value (Dec)
40201	Set Point	R	–
40202	Actual	R	–
40203	Pump Speed	R	–
40204	Wire to Water Power	R	–
40205	Set Point #1	R	–
40206	Set Point #2	R	–
40207	Energy Savings	R	–
40208	Pump Number	R	Stopped [0]
			Pump 1 [1]
			Pump 2 [2]
			Pump 3 [3]
			Pump 4 [4]
40209	Used Set Point	R	–

Group 3	VFD Signal	R/W	Set Value (Hex)
40301	FB CMD Word 1	R	–
40302	FB CMD Word 2	R	–
40303	FB STS Word 1	R	–
40304	FB STS Word 2	R	–
40305	Fault Word 1	R	–
40306	Fault Word 2	R	–
40307	Fault Word 3	R	–
40308	Alarm Word 1	R	HEX
40309	Alarm Word 2	R	HEX
40310	AV Alarm Word	R	HEX
40311	AV Fault Word	R	–

4XXXX REGISTER MAPPING

DRIVE PARAMETERS

Group 10	VFD Signal	R/W	Set Value (Dec)
41001	Parameter Lock	R/W	Locked [0], Open [1]
41002	Pass Code	R/W	
41003	Local Lock	R/W	Off [0], On [1]
41004	Parameter Save	R/W	Done [0], Save... [1]
41005	New Pass Code	R/W	
41006	Set Point Lock	R/W	Off [0], On [1]
Group 11	VFD Signal	R/W	Set Value (Dec)
41101	Language	R/W	English [0]
			Espanol [1]
			Francais [2]
41102	Application Macro	R/W	Single Pump [1]
			Synchronous [2]
			Multicontrol [3]
			Constant Slv [4]
			Speed Contrl [5]
41103	Motor Nom Voltage	R/W	
41104	Motor Nom Current	R/W	
41105	Motor Nom Freq	R/W	
41106	Motor Nom RPM	R/W	
41107	Motor Nominal Power	R/W	
Group 12	VFD Signal	R/W	Set Value (Dec)
41201	Start/Stop	R/W	Keypad [0]
			Fieldbus [1]
41202	Auto Restart	R/W	On [0], Off [1]
41203	Test Run	R/W	Not Sel [0]
			Auto [1]
			Manual [2]
41204	Test Speed % (FL)	R/W	
41205	Test Run Delay	R/W	
41206	Motor Jog	R/W	Disable [0]
			Jog [1]
Group 13	VFD Signal	R/W	Set Value (Dec)
41301	Ramp1 Fast Accel	R/W	
41302	Ramp2 Fast Decel	R/W	
41303	Ramp3 Slow Accel	R/W	
41304	Ramp4 Slow Decel	R/W	
41305	Ramp Hysteresis	R/W	
41306	Reg Window	R/W	

4XXXX REGISTER MAPPING

DRIVE PARAMETERS

Group 14	VFD Signal	R/W	Set Value (Dec)
41401	Maximum Freq	R/W	
41402	Minimum Freq	R/W	
41403	Config Speed Min	R/W	0 [0]
			Minimum Freq [1]
41404	Stp Dely Min Spd	R/W	
41405	Restart Value	R/W	
41406	Restart Delay	R/W	
41407	Priming Delay	R/W	
Group 15	VFD Signal	R/W	Set Value (Dec)
41501	Transducer Unit	R/W	% [4]
			C [9]
			F [16]
			GPM [24]
			PSI [25]
			ft [27]
41502	Transducer Max	R/W	
41503	Transducer Min	R/W	
41506	Sensor Min	R/W	4 mA [0]
			Tune [1]
Group 16	VFD Signal	R/W	Set Value (Dec)
41601	Sp1/Sp2 Select	R/W	Setp1 [0]
			DI4 [1]
			Fieldbus [2]
41602	Set Point 1 Sel	R/W	Keypad [0]
			AI1 [1]
			Fieldbus [2]
41603	Set Point 2 Sel	R/W	Keypad [0]
			AI1 [1]
			Fieldbus [2]
41604	AI1 Minimum	R/W	0V [0]
			4 mA [1]
			Tune [2]
Group 18	VFD Signal	R/W	Set Value (Dec)
41801	Relay Output 1	R/W	Not Sel [0]
			Run [1]
			Ready [2]
			Fault [3]
			Low Water [4]
			Pump Prtct [5]
			Start Slv [6]
			Stand By [7]
	Active [8]		
41802	RO 1 On Delay	R/W	
41803	RO 1 Off Delay	R/W	

4XXXX REGISTER MAPPING

DRIVE PARAMETERS

Group 18	VFD Signal	R/W	Set Value (Dec)
41804	Relay Output 2	R/W	Not Sel [0]
			Run [1]
			Ready [2]
			Fault [3]
			Low Water [4]
			Pump Prtct [5]
			Start Slv [6]
			Stand By [7]
41805	RO 2 On Delay	R/W	Active [8]
41806	RO 2 Off Delay	R/W	
41807	Relay Output 3	R/W	Not Sel [0]
			Run [1]
			Ready [2]
			Fault [3]
			Low Water [4]
			Pump Prtct [5]
			Start Slv [6]
			Stand By [7]
41808	RO 3 On Delay	R/W	Active [8]
41809	RO 3 Off Delay	R/W	
Group 19	VFD Signal	R/W	Set Value (Dec)
41901	AO1 Content Sel	R/W	Not Sel [0]
			Motor Freq [101]
			Motor Curren [102]
			Motor Power [103]
			Actual [202]
			Energy Savin [207]
41902	AO1 Content Min	R/W	
41903	AO1 Content Max	R/W	
41904	Minimum AO1	R/W	
41905	Maximum AO1	R/W	
41906	AO2 Content Sel	R/W	Not Sel [0]
			Motor Freq [101]
			Motor Curren [102]
			Motor Power [103]
			Actual [202]
			Energy Savin [207]
41907	AO2 Content Min	R/W	
41908	AO2 Content Max	R/W	
41909	Minimum AO2	R/W	
41910	Maximum AO2	R/W	

4XXXX REGISTER MAPPING

DRIVE PARAMETERS

Group 21	VFD Signal	R/W	Set Value (Dec)
42101	Regulation Mode	R/W	Normal [0]
			Inverse [1]
42102	Press Inc Speed	R/W	
42103	Press Inc	R/W	
Group 22	VFD Signal	R/W	Set Value (Dec)
42201	Value Decrease	R/W	
42202	Value Increase	R/W	
42203	Enable Sequence	R/W	
42204	Switch Lead Lag	R/W	
42205	Sync Limit	R/W	
42206	Sync Window	R/W	
42207	Pump Address	R/W	
42209	Setp2 Source	R/W	Off [0]
			Addr 1 [1]
			Addr 2 [2]
			Addr 3 [3]
			Addr 4 [4]
Group 24	VFD Signal	R/W	Set Value (Dec)
42401	Keypad Failure	R/W	Fault [1]
			Disable [3]
42402	Pump Protct Ctrl	R/W	Disable [0]
			Warning [1]
			Warning & Ct [2]
42403	Protection Limit	R/W	
42404	Protection Delay	R/W	
42405	Low Water	R/W	Disable [0]
			Warning [1]
			Warn & Ctrl [3]
42406	Error Reset	R/W	
42407	Reset Delay	R/W	
42408	Run Enable	R/W	Disable [0]
			Enable [1]
42409	Comm Fault Func	R/W	Not Sel [0]
			Fault [1]
42410	Comm Fault Time	R/W	Last Speed [3]

4XXXX REGISTER MAPPING

DRIVE PARAMETERS

Group 25	VFD Signal	R/W	Set Value (Dec)
42501	NR of Trials	R/W	
42502	Trial Time	R/W	
42503	Delay Time	R/W	
42504	AR Overcurrent	R/W	Disable [0]
			Enable [1]
42505	AR Undercurrent	R/W	Disable [0]
			Enable [1]
42506	AR Undervoltage	R/W	Disable [0]
			Enable [1]
42507	AR AI<Min	R/W	Disable [0]
			Enable [1]
Group 26	VFD Signal	R/W	Set Value (Dec)
42601	Energy Cost	R/W	
42602	Baseline Power	R/W	
42603	Saving Scale	R/W	
42604	Energy Save Mthd	R/W	Savings Op1 [0]
			Savings Op2 [1]
42605	Reset Counters	R/W	No [0]
Group 30	VFD Signal	R/W	Set Value (Dec)
43001	Comm Prot Sel	R/W	Not Sel [0]
			Std Modbus [1]
			Aquavar [3]
			Ext Fba [4]
Group 31	VFD Signal	R/W	Set Value (Dec)
NOTE: This group is setup by automatically an External Fieldbus Adaptor. Refer to the External Fieldbus Adaptor manual for more information.			

4XXXX REGISTER MAPPING

DRIVE PARAMETERS

Group 32	VFD Signal	R/W	Set Value (Dec)
43201	EFB Protocol ID	R/W	Do not edit!
43202	EFB Station ID	R/W	
43203	EFB Baud Rate	R/W	
43204	EFB Parity	R/W	8N1 [0]
			8N2 [1]
			8E1 [2]
			8O1 [3]
43205	EFB CTRL Profile	R/W	ABB Drives [0]
			ACS550 [1]
43206	EFB OK Messages	R/W	
43207	EFB CRC Errors	R/W	
43208	EFB UART Errors	R/W	
43209	EFB Status	R/W	Idle [0]
			Execut Init [1]
			Time Out [2]
			Config Error [3]
			Off-Line [4]
			On-Line [5]
			Reset [6]
	Listen Only [7]		
43210	EFB Par 10	R/W	
43211	EFB Par 11	R/W	
43212	EFB Par 12	R/W	
43213	EFB Par 13	R/W	
43214	EFB Par 14	R/W	
43215	EFB Par 15	R/W	
43216	EFB Par 16	R/W	
43217	EFB Par 17	R/W	
43218	EFB Par 18	R/W	
43219	EFB Par 19	R/W	
43220	EFB Par 20	R/W	
Group 33	VFD Signal	R/W	Set Value (Dec)
43301	Station ID	R/W	
43302	Baud Rate	R/W	
43303	Parity	R/W	8N1 [0]
			8N2 [1]
			8E1 [2]
			8O1 [3]
43304	OK Messages	R/W	
43305	Parity Errors	R/W	
43306	Frame Errors	R/W	
43307	Buffer Overruns	R/W	
43308	CRC Errors	R/W	

4XXXX REGISTER MAPPING

DRIVE PARAMETERS

Group	VFD Signal	R/W	Set Value (Dec)
45001	Switching Freq	R/W	

Group 51	VFD Signal	R/W	Set Value (Dec)
45101	Cooling Fan Trig	R/W	
45102	Cooling Fan Act	R/W	
45103	Revolution Trig	R/W	
45104	Revolution Act	R/W	
45105	Run Time Trig	R/W	
45106	Run Time Act	R/W	
45107	User MWh Trig	R/W	
45108	User MWh Act	R/W	

Group 99	VFD Signal	R/W	Set Value (Dec)
49901	FW Version	R	
49902	Drive Rating	R	

Supported Function Codes

- 03 - Read 4xxxx Registers
- 06 - Preset Single 4xxxx Register
- 16 - Preset Multiple 4xxxx Registers (0x10 Hex)
- 23 - Read/Write 4xxxx Registers (0x17 Hex)

CENTRIPRO LIMITED WARRANTY

This warranty applies to all Aquavar CPC controllers manufactured by Xylem, Inc.

Any part or parts found to be defective within the warranty period shall be replaced at no charge to the dealer during the warranty period. The warranty period shall exist for a period of twenty-four (24) months from date of installation or thirty (30) months from date of manufacture, whichever period is shorter.

A dealer who believes that a warranty claim exists must contact the authorized CentriPro distributor from whom the controller was purchased and furnish complete details regarding the claim. The distributor is authorized to adjust any warranty claims utilizing the CentriPro Customer Service Department.

The warranty excludes:

- (a) Labor, transportation and related costs incurred by the dealer;
- (b) Reinstallation costs of repaired equipment;
- (c) Reinstallation costs of replacement equipment;
- (d) Consequential damages of any kind; and,
- (e) Reimbursement for loss caused by interruption of service.

For purposes of this warranty, the following terms have these definitions:

- (1) "Distributor" means any individual, partnership, corporation, association, or other legal relationship that stands between CentriPro and the dealer in purchases, consignments or contracts for sale of the subject controllers.
- (2) "Dealer" means any individual, partnership, corporation, association, or other legal relationship which engages in the business of selling or leasing controllers to customers.
- (3) "Customer" means any entity who buys or leases the subject controllers from a dealer. The "customer" may mean an individual, partnership, corporation, limited liability company, association or other legal entity which may engage in any type of business.

THIS WARRANTY EXTENDS TO THE DEALER ONLY.



Xylem, Inc.
2881 East Bayard Street Ext., Suite A
Seneca Falls, NY 13148
Phone: (800) 453-6777
Fax: (888) 322-5877
www.centripro.com

CentriPro and Aquavar are trademarks of Xylem Inc. or one of its subsidiaries.
© 2012 Xylem Inc. ADAQCPC R1 February 2013