

(H)3x2x11F-S – 8100 SERIES

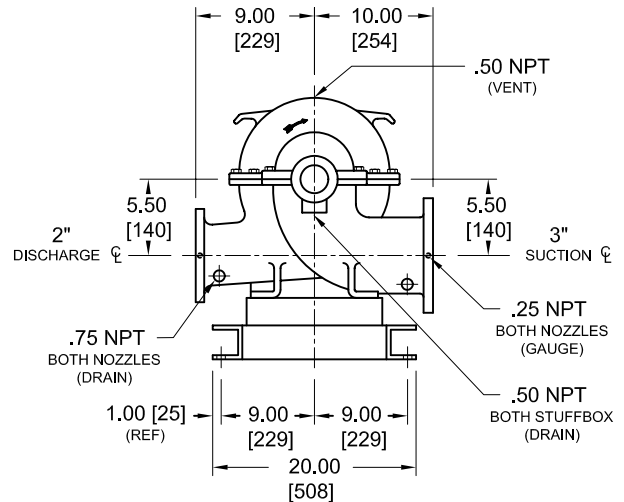

CW ROTATION VIEWED FROM COUPLING END

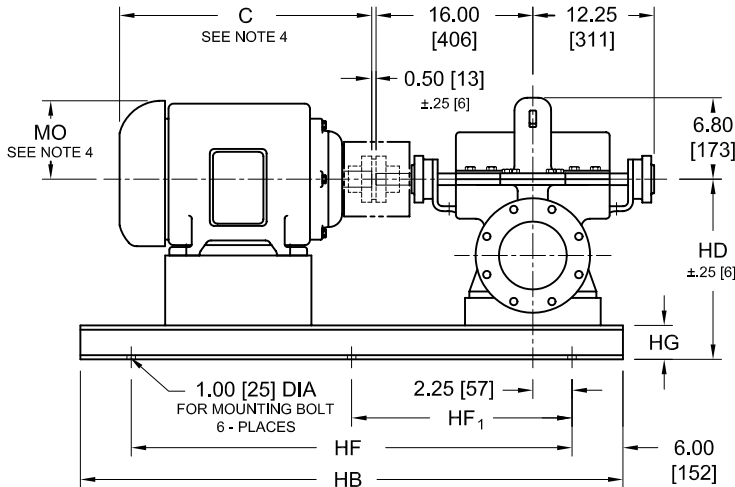
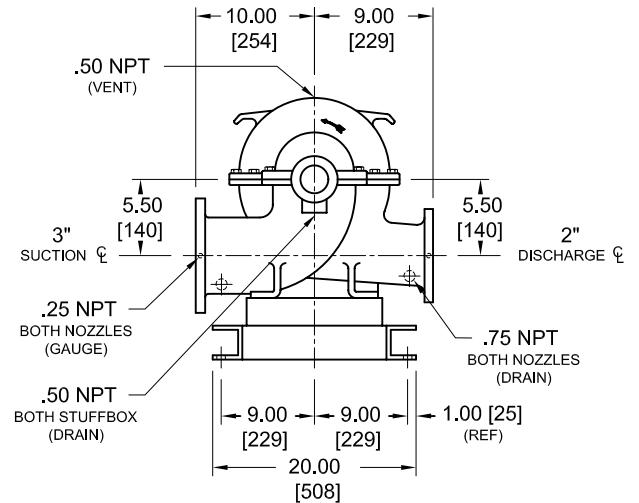

CCW ROTATION VIEWED FROM COUPLING END

MOTOR FRAME	C	MO	HB	HF	HF ₁	HD	HG
213	17.80 [453]	6.00	48.00 [1220]	36.00 [915]	18.00 [458]	15.25 [388]	4.00 [102]
215	19.30 [491]	[153]					
254	23.30 [592]	7.10	54.00 [1372]	42.00 [1067]	21.00 [534]		
256	25.00 [635]	[181]					
284	24.80 [630]	7.80					
286	26.30 [669]	[199]					
324	28.20 [717]	8.60					
326	29.70 [755]	[219]					
364	30.00 [762]	9.20					
365	31.00 [788]	[234]					

NOTES:

- ALL DIMENSIONS ARE INCHES [mm].
- SUCTION AND DISCHARGE CONNECTIONS ARE DRILLED PER 125# ANSI B16.1. PUMPS WITH "H" PREFIX HAVE DISCHARGE CONNECTION DRILLED PER 250# ANSI B16.1. FLANGE HOLES STRADDLE CENTERLINE.
- BASE PLATE SETTING (BEFORE PIPING), GROUTING PROCEDURES, AND FINAL ALIGNMENT MUST BE IN ACCORDANCE WITH A-C FIRE PUMPS SYSTEMS RECOMMENDED PROCEDURES OUTLINED IN THE INSTRUCTION MANUAL ASSOCIATED WITH THIS PUMP TYPE.
- MOTOR DIMENSIONS ARE APPROXIMATE FOR A GIVEN NEMA FRAME. CONSULT FACTORY IF SPACE IS LIMITED.
- BOTH SUCTION AND DISCHARGE PIPES MUST BE SUPPORTED INDEPENDENTLY NEAR THE PUMP TO REDUCE STRAIN ON THE PUMP CASING. ALSO EXPANSION JOINTS, IF USED, MUST NOT EXERT FORCE ON CASING.
- COUPLING GUARD MEETS ANSI/OSHA REQUIREMENTS.
- CONSULT FACTORY FOR BASE MOUNTED CONTROLLER.

NOT FOR CONSTRUCTION, INSTALLATION OR APPLICATION PURPOSES UNLESS CERTIFIED										
CERTIFIED FOR:							APPROVAL	UL	FM	ULC
							<input type="checkbox"/>	<input type="checkbox"/>	<input type="checkbox"/>	
CUSTOMER ORDER NO.:				TAG NO.			FLANGES			
PUMP DATA	SIZE	MODEL	CURVE NO.	GPM	HEAD	ROTATION	SUCTION	DISCH.		
MOTOR DATA	HP	RPM	VOLTS	PHASE	HERTZ	FRAME SIZE	ENCLOSURE			
SHOP ORDER:			CERTIFIED BY:			DATE:				