



ITT

TID

Wastewater

Goulds Pumps

TYPICAL INSTALLATION DRAWING – Simplex Submersible Sewage Pump – 3" and 4" NPT Discharge

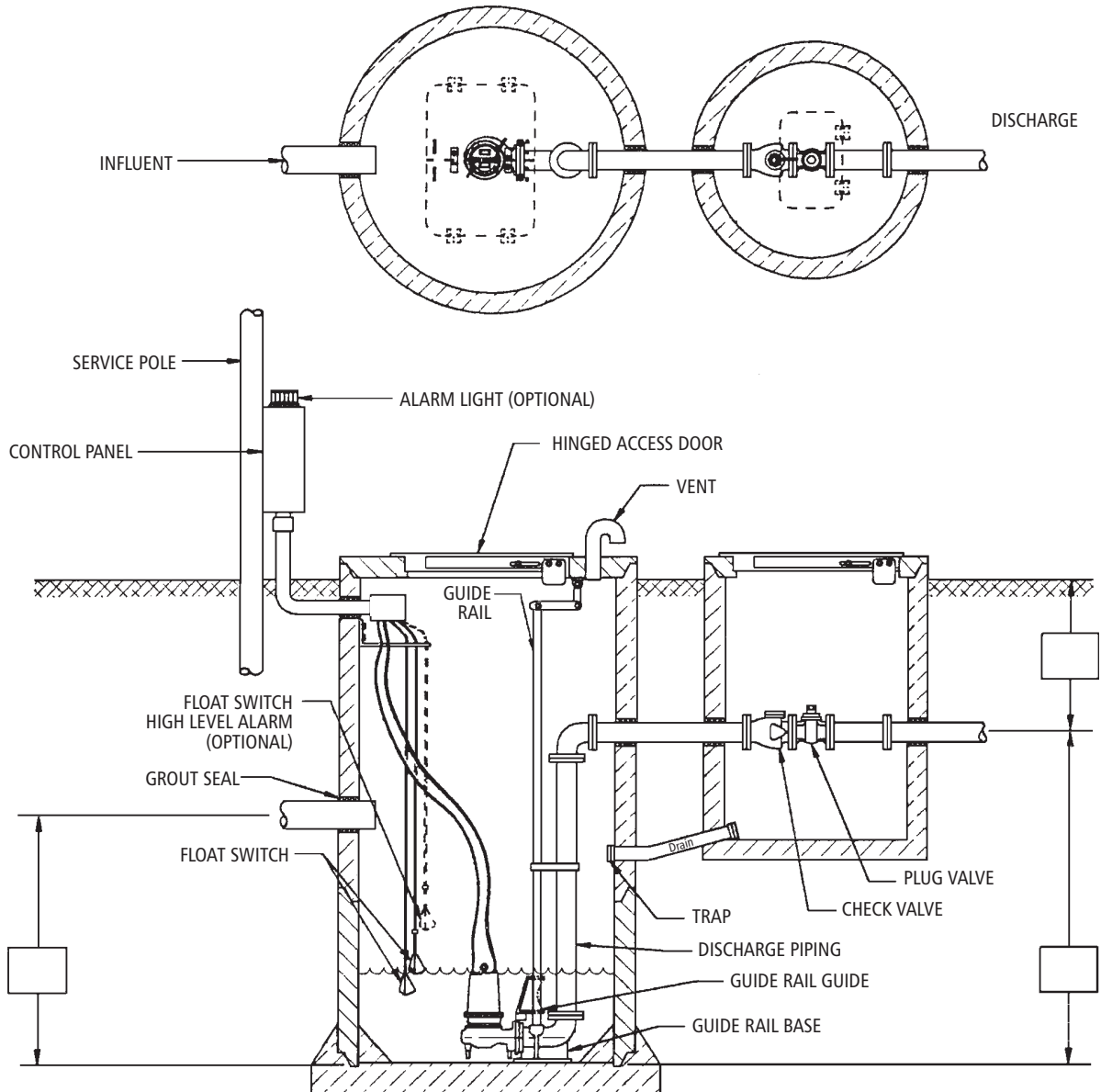

(All dimensions are in inches. Do not use for construction purposes.)



Goulds Pumps is a brand of ITT Corporation.

www.goulds.com

Engineered for life

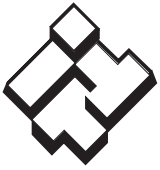

ITT

GOULDS PUMPS Wastewater

TYPICAL INSTALLATION DRAWING – Duplex Submersible Sewage Pump – 3" and 4" NPT Discharge

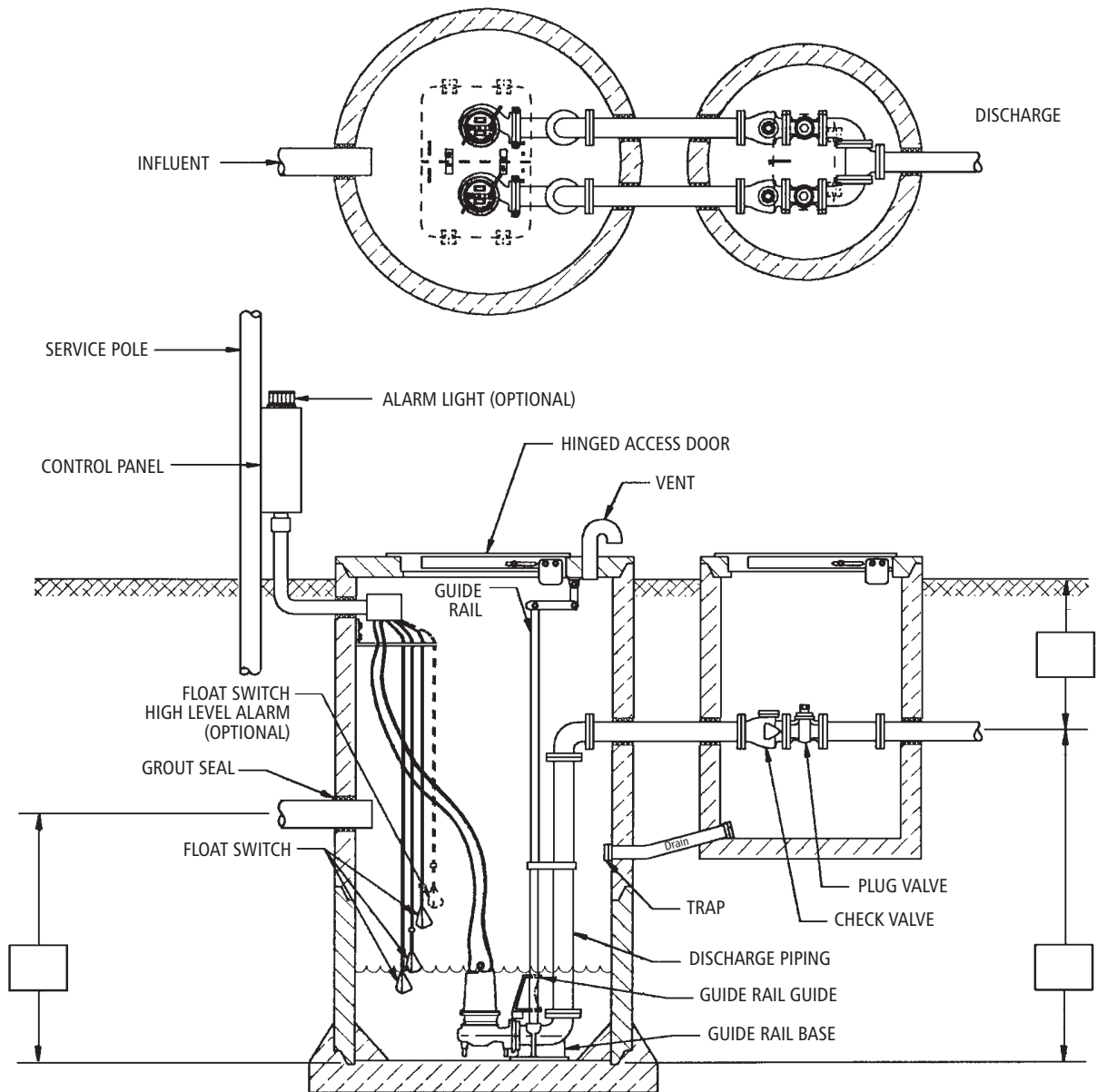

(All dimensions are in inches. Do not use for construction purposes.)

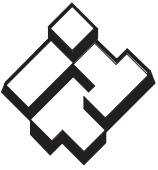

ITT

GOULDS PUMPS Wastewater

TYPICAL INSTALLATION DRAWING – 1GD Submersible Grinder Pump – 1 1/4" Discharge Slide Rail (A10-12)

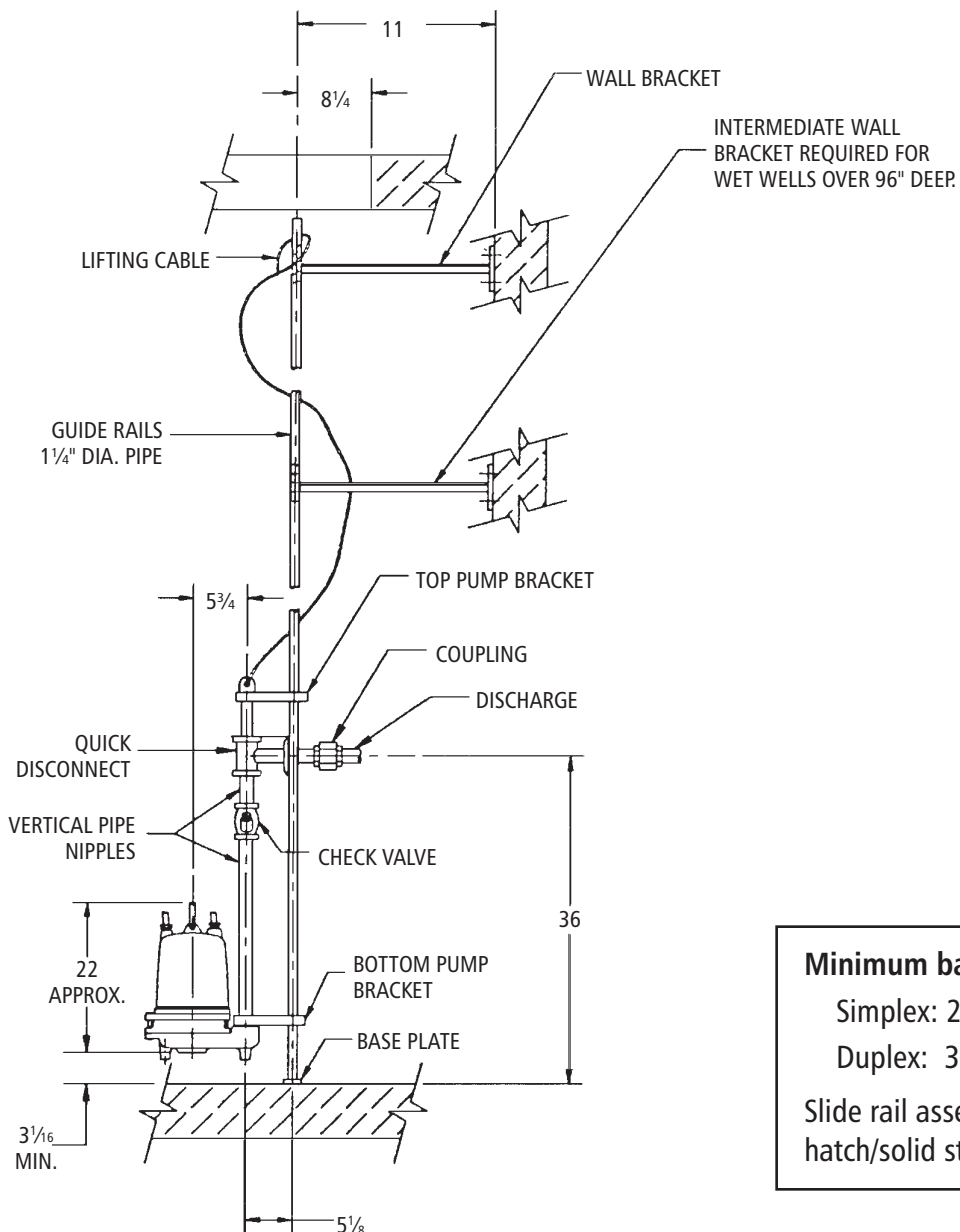

Minimum basin diameters
Simplex: 24"
Duplex: 36"
Slide rail assemblies must use hatch/solid style covers.

(All dimensions are in inches. Do not use for construction purposes.)

**To use catalog 1 1/4" Duplex Discharge Piping.



ITT

GOULDS PUMPS
Wastewater

TYPICAL INSTALLATION DRAWING – 3SD Submersible Sewage Pump – 3 x 4 Slide Rail (A10-30 assembly)

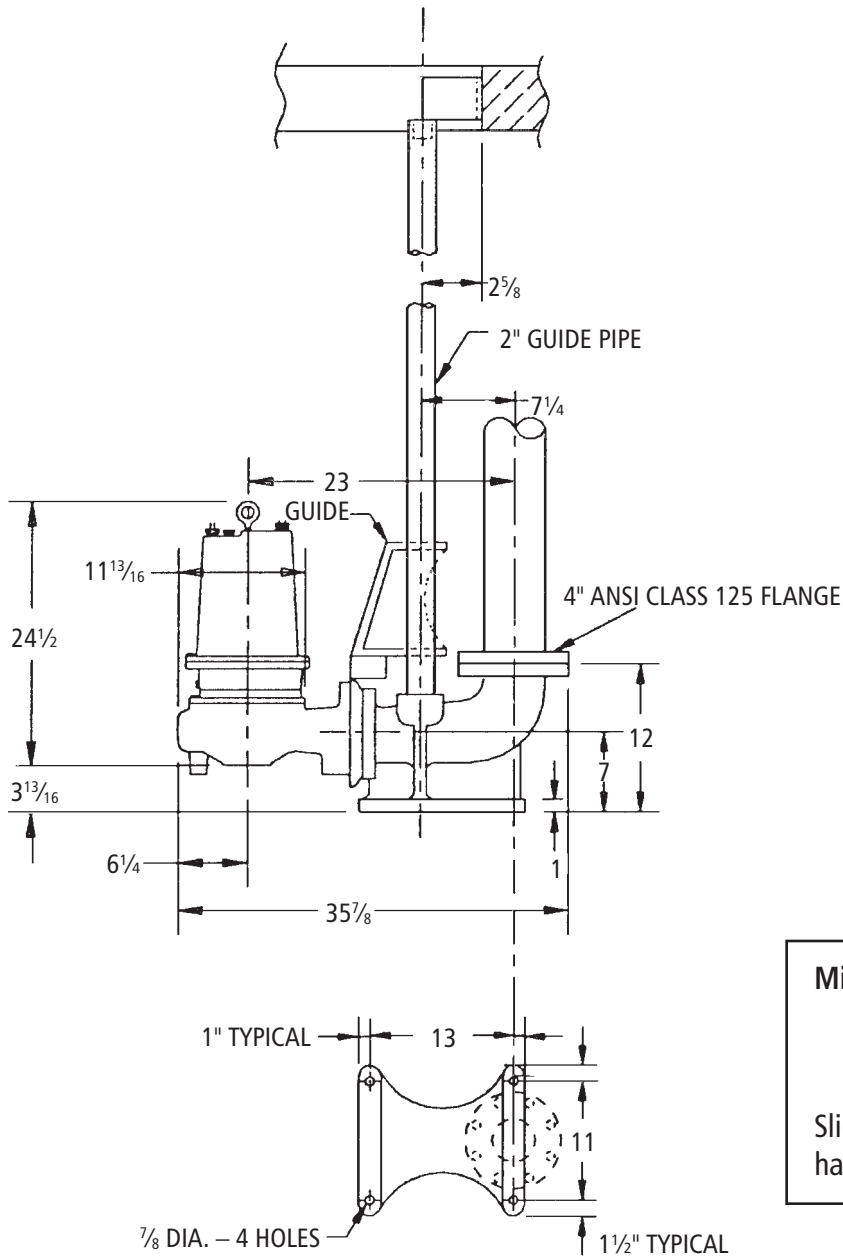

Minimum basin diameters

Simplex: 36"

Duplex: 48"

Slide rail assemblies must use hatch door style covers.

(All dimensions are in inches. Do not use for construction purposes.)



ITT

GOULDS PUMPS
Wastewater

TYPICAL INSTALLATION DRAWING – 3888D4/4SD

Submersible Sewage Pump – with A10-40 Guide Rail

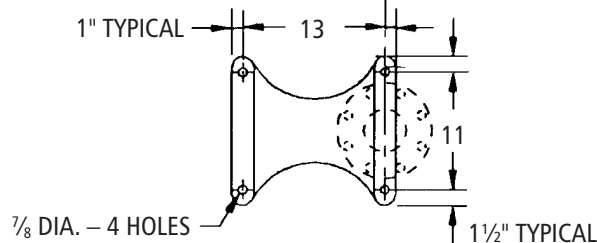
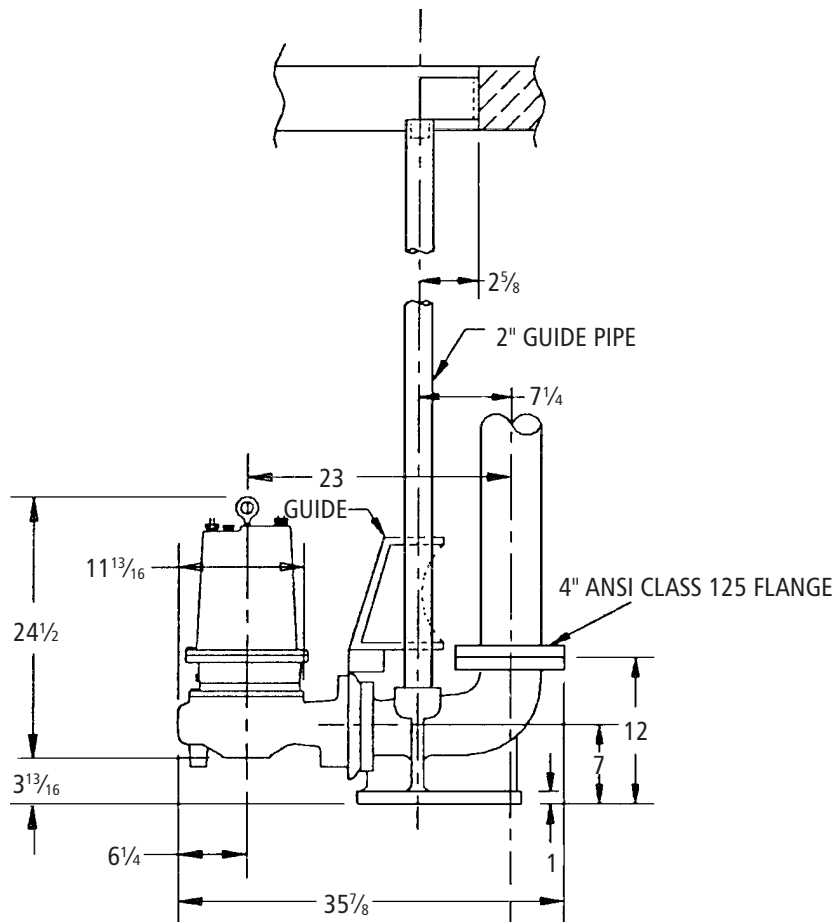

Minimum basin diameters

Simplex: 36"

Duplex: 48"

Must use hatch cover to remove
slide rail assemblies.

(All dimensions are in inches. Do not use for construction purposes.)

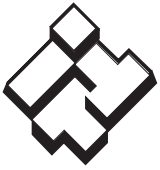

ITT

GOULDS PUMPS
Wastewater

TYPICAL INSTALLATION DRAWING – 4NS/4XD Submersible Sewage Pump – on A10-40 Guide Rail

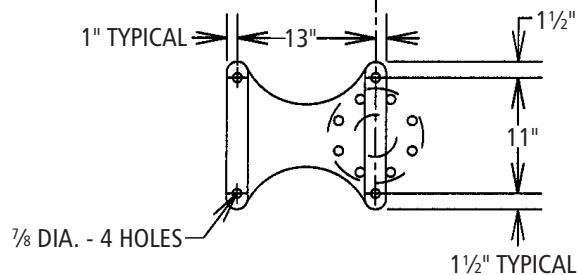
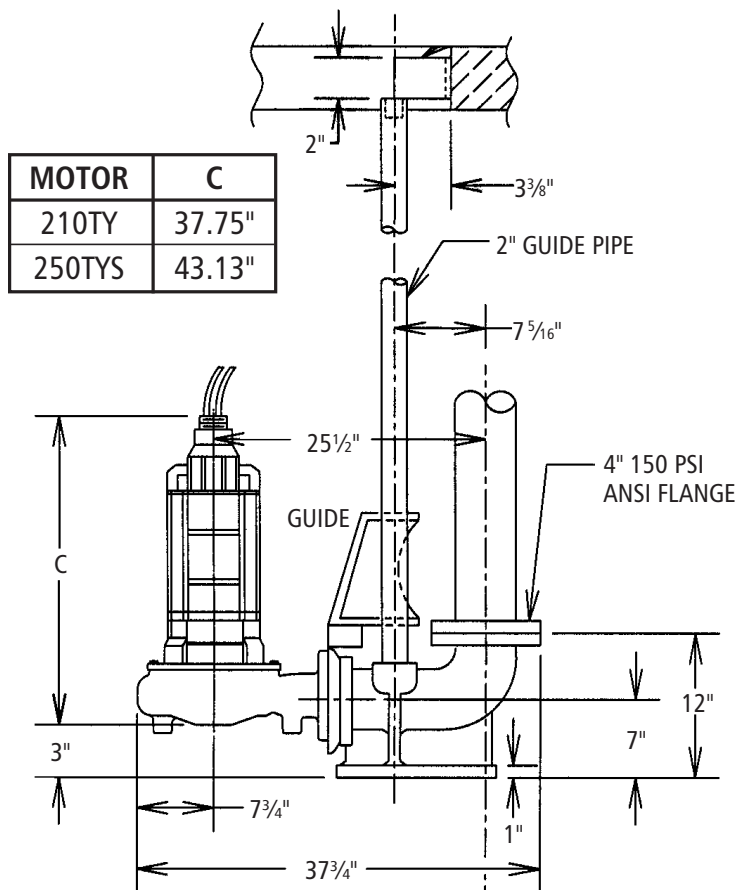

Minimum basin diameters

Simplex: 36"

Duplex: 48"

Slide rail assemblies must use hatch door style covers.

(All dimensions are in inches. Do not use for construction purposes.)



ITT

GOULDS PUMPS Wastewater

TYPICAL INSTALLATION DRAWING – 2ED/2WD Submersible Sewage Pump – (A10-20 slide rail)

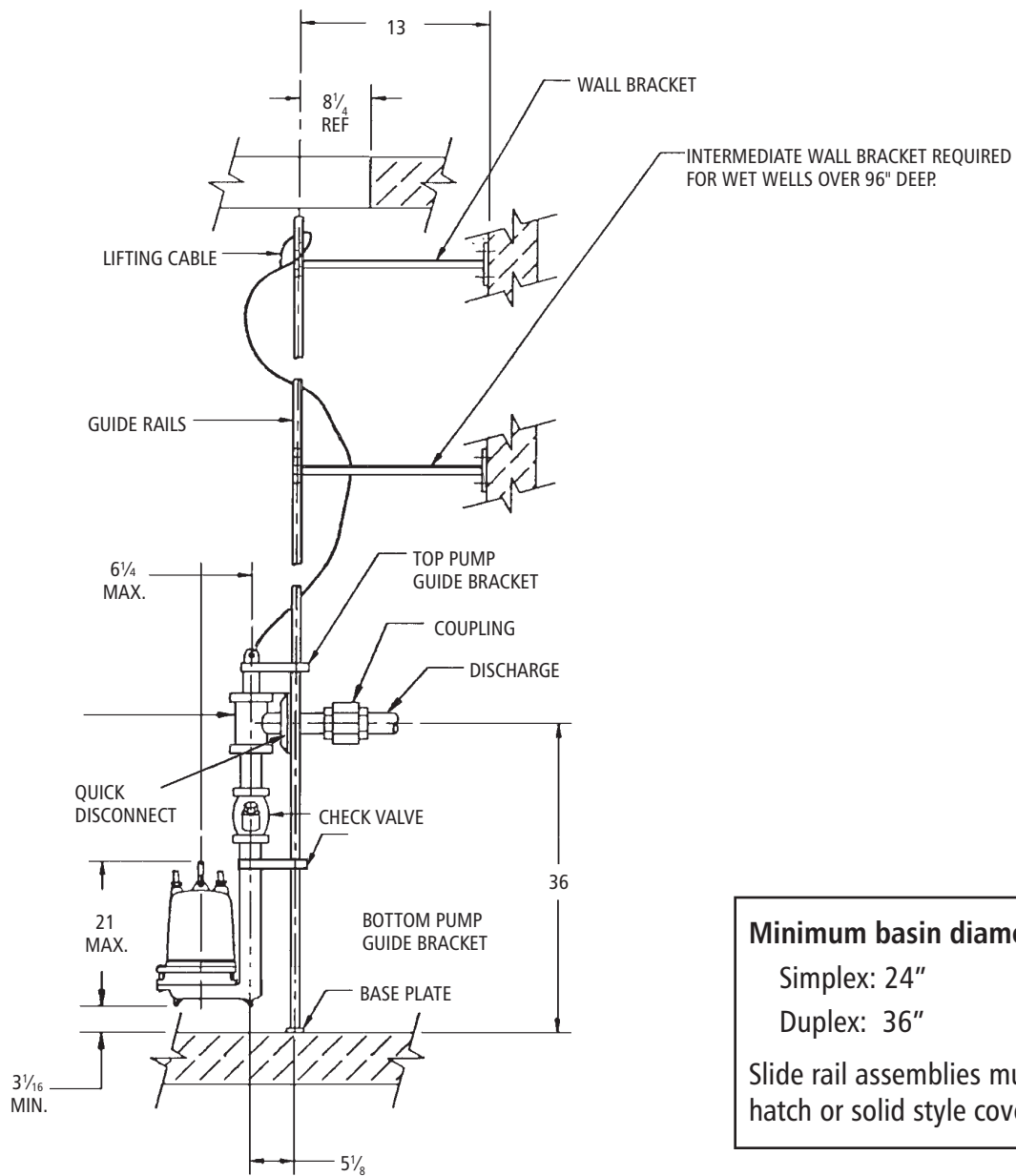

Minimum basin diameters
Simplex: 24"
Duplex: 36"
Slide rail assemblies must use hatch or solid style covers.

(All dimensions are in inches. Do not use for construction purposes.)
**To use Catalog 2" Duplex Discharge Piping



Wastewater



Goulds Pumps and the ITT Engineered Blocks Symbol are registered trademarks and tradenames of ITT Corporation.
SPECIFICATIONS ARE SUBJECT TO CHANGE WITHOUT NOTICE.

TID May, 2008
© 2008 ITT Corporation

Engineered for life